

STRATA PLAN OF LOT A, EXCEPT PART  
 IN PHASE I, STRATA PLAN VR 2055  
 BLOCK 'A' D.L. 5316, PLAN 2152G  
 GROUP 1, N.W.D.

FIRST SHEET SHEET 1 OF 41 SHEETS

STRATA PLAN VR 2055  
 DEPOSITED AND REGISTERED IN THE LAND  
 TITLE OFFICE AT VANCOUVER, B.C.,  
 THIS 25<sup>th</sup> DAY OF NOVEMBER, 1988.

SCALE 1 : 1000

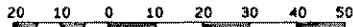

THIS PLAN LIES WITHIN THE SQUAMISH-LILLOOET REGIONAL DISTRICT

RESORT MUNICIPALITY OF WHISTLER

THE ADDRESS FOR SERVICE OF DOCUMENTS ON  
 THE STRATA CORPORATION IS:-

THE OWNERS STRATA PLAN VR 2055  
 C/O 2225 FOLKSTONE WAY  
 WEST VANCOUVER B.C.  
 V7S 2Y6

*[Signature]*  
 DEPUTY REGISTRAR

PHASE II GB 135194

CIVIC ADDRESS : SNOWRIDGE CRESCENT

D.L. 4979

D.L. BLOCK PLAN 13162 C 14 23 65  
 12 13 14 23 65

PLAN 19851

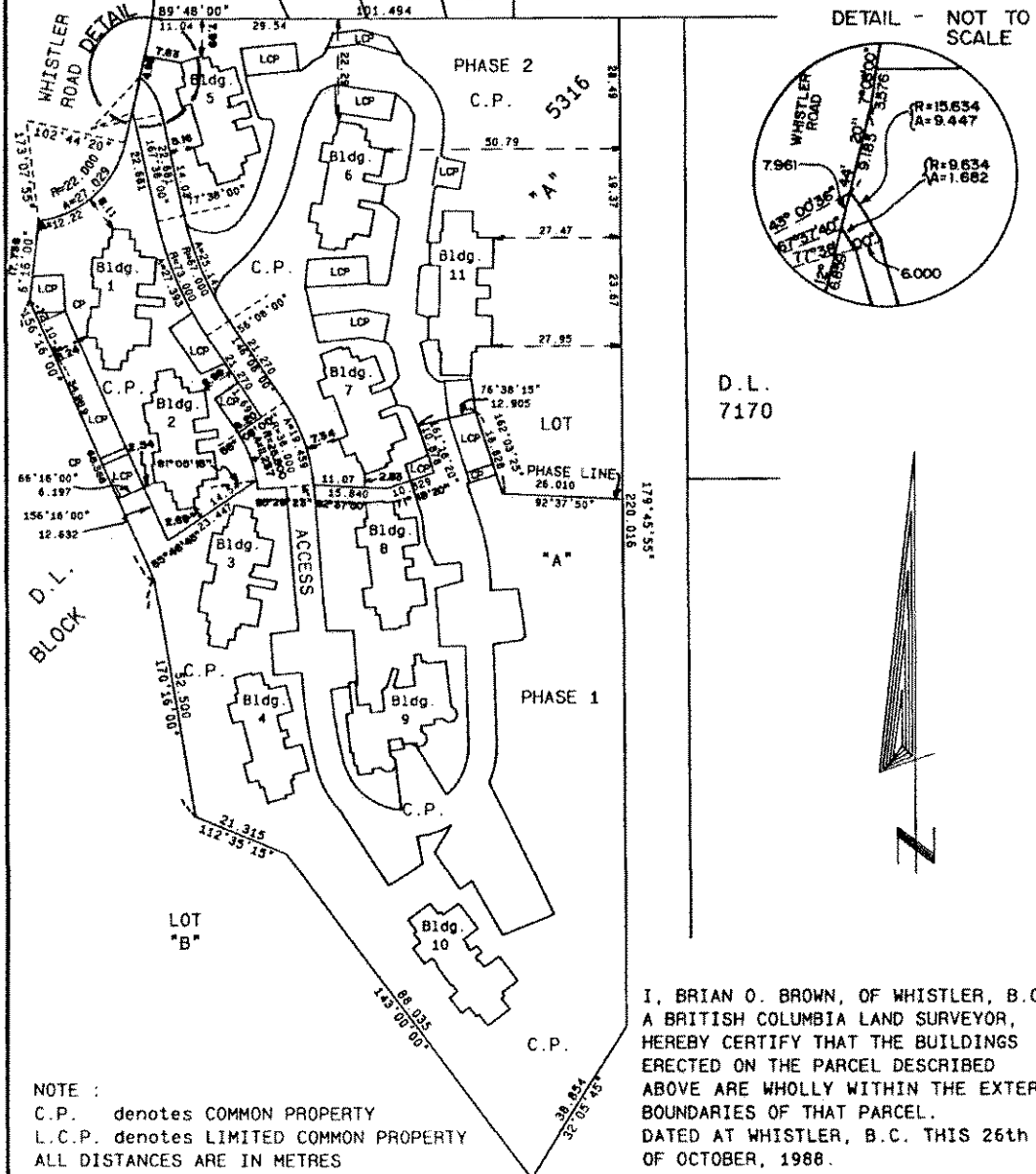

D.L. 7170

NOTE :  
 C.P. denotes COMMON PROPERTY  
 L.C.P. denotes LIMITED COMMON PROPERTY  
 ALL DISTANCES ARE IN METRES

I, BRIAN O. BROWN, OF WHISTLER, B.C.,  
 A BRITISH COLUMBIA LAND SURVEYOR,  
 HEREBY CERTIFY THAT THE BUILDINGS  
 ERECTED ON THE PARCEL DESCRIBED  
 ABOVE ARE WHOLLY WITHIN THE EXTERNAL  
 BOUNDARIES OF THAT PARCEL.  
 DATED AT WHISTLER, B.C. THIS 26<sup>th</sup> DAY  
 OF OCTOBER, 1988.

Robert B. Brown & Associates  
 Professional Land Surveyors  
 P.O. Box 13, Whistler, B.C.  
 V0N 1B0 932 - 5426

*[Signature]* B.C.L.S.

J87026

SP88306B

L82418 2003-10-16-11.54.16.480949

VAVAS2055

FILED

CONDOMINIUM ACT  
PHASE II

STRATA PLAN VR 2055

		FORM 1 SECTION 3(1)(f)	FORM 2 SECTION 3(1)(g)	FORM 3 SECTION 3(1)(h)
LOT	SHEET	SCHEDULE OF UNIT ENTITLEMENT	SCHEDULE OF INTEREST UPON DESTRUCTION	SCHEDULE OF VOTING RIGHTS
NO.	NO.	UNIT ENTITLEMENT	INTEREST UPON DESTRUCTION	NUMBER OF VOTES
26	485	117	137	
27	485	124	125	
28	485	124	125	
29	485	117	137	
30	687	127	162	
31	687	127	162	
32	889	117	143	
33	889	124	131	
34	889	124	131	
35	889	117	143	
36	10811	127	168	
37	10811	127	168	
38	12	113	149	
39	13814	129	181	
40	12	113	149	
41	13814	129	181	
42	16	110	181	
43	17818	126	199	
44	15	113	149	
45	16	108	181	
46	17818	126	199	
47	19	113	149	
48	20	108	187	
49	21822	126	206	
50	19	113	149	
51	20	108	187	
52	21822	125	206	
53	24	116	168	
54	23242526	191	225	
55	24	101	168	
56	25826	149	225	
PHASE 2 AGGREGATE		3789	5171	
PHASE 1 AGGREGATE		2884	4829	
AGGREGATE		6673	10000	

ACCEPTED AS TO FORMS 1, 2 & 3  
This 21 Day of November 1988.

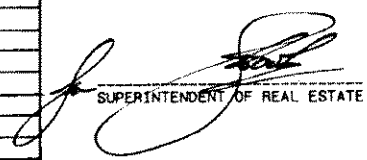
  
SUPERINTENDENT OF REAL ESTATE

 B.C.L.S.  
October 26 1988

Robert B. Brown & Associates  
Professional Land Surveyors  
P.O. Box 13, Whistler, B.C.  
V0N 1B0 932 - 5426

L82418 2003-10-16-11.54.16.480949

VAVAS2055

FILED

CONDOMINIUM ACT  
PHASE II

STRATA PLAN VR 2055

STATUTORY DECLARATION

I, THE UNDERSIGNED, DO SOLEMNLY DECLARE THAT:-

- (1) I, THE UNDERSIGNED, AM THE DULY AUTHORIZED AGENT OF THE OWNER DEVELOPER
- (2) THE STRATA PLAN IS ENTIRELY FOR RESIDENTIAL USE

I MAKE THIS SOLEMN DECLARATION CONSCIENTIOUSLY BELIEVING IT TO BE TRUE, AND KNOWING THAT IT IS OF THE SAME FORCE AND EFFECT AS IF MADE UNDER OATH.

DECLARED BEFORE ME AT - Vancouver  
IN THE PROVINCE OF BRITISH COLUMBIA  
THIS 1st DAY OF November, 1988.

*[Signature]*  
-----  
COMMISSIONER FOR TAKING AFFIDAVITS WITHIN THE PROVINCE OF BRITISH COLUMBIA

*[Signature]*  
-----  
COMMISSIONER FOR TAKING AFFIDAVITS WITHIN THE PROVINCE OF BRITISH COLUMBIA

SIGNATURES

OWNER

INTERNATIONAL LAND CORPORATION LTD.

*[Signature]*  
-----  
AUTHORIZED SIGNATORY  
*[Signature]*  
-----  
AUTHORIZED SIGNATORY

APPROVED AS PHASE 2 OF A 2 PHASE STRATA PLAN UNDER THE "CONDOMINIUM ACT" THIS 9 DAY OF NOVEMBER 1988

*[Signature]*  
-----  
APPROVING OFFICER-RESORT MUNICIPALITY OF WHISTLER

MORTGAGEE

THE TORONTO-DOMINION BANK  
(By it's Attorneys in fact)  
*Power of Attorney # R107477*

*[Signature]*  
-----  
AUTHORIZED SIGNATORY  
*[Signature]*  
-----  
AUTHORIZED SIGNATORY

OPTION TO PURCHASE R41366

WHISTLER MOUNTAIN SKI CORPORATION

*[Signature]*  
-----  
AUTHORIZED SIGNATORY  
*[Signature]*  
-----  
AUTHORIZED SIGNATORY

*[Signature]*  
-----  
WITNESS AS TO BOTH SIGNATURES  
*Shirley Tautscher*  
*700 W. Georgia St.*  
*Vancouver, B.C.*  
-----  
ADDRESS

*Bank Officer*  
-----  
OCCUPATION

I, BRIAN O. BROWN OF THE MUNICIPALITY OF WHISTLER, BRITISH COLUMBIA LAND SURVEYOR, HEREBY CERTIFY THAT THE BUILDINGS SHOWN IN THIS STRATA PLAN HAVE NOT, AS OF THE 26th DAY OF OCTOBER, 1988 BEEN PREVIOUSLY OCCUPIED. DATED AT WHISTLER, BRITISH COLUMBIA THIS 26th DAY OF OCTOBER, 1988.

*[Signature]* B.C.L.S.

*[Signature]* B.C.L.S.  
October 26 1988

Robert B. Brown & Associates  
Professional Land Surveyors  
P.O. Box 13, Whistler, B.C.  
VON 180 932 - 5426

FILED VAVAS2055 L82418 2003-10-16-11:54:16.480949

PLAN OF STRATA LOTS 26-29  
PHASE II

STRATA PLAN VR 2055

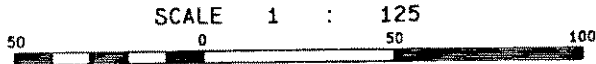

BUILDING 1  
GROUND FLOOR

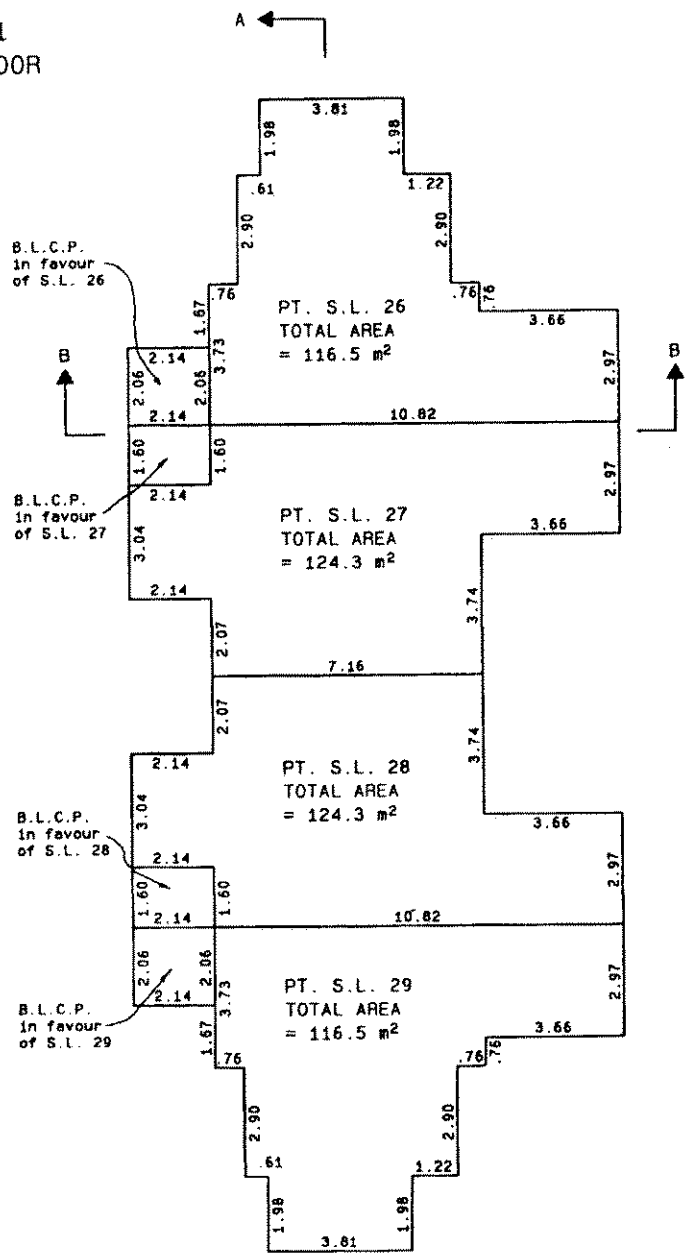

NOTE:  
 S.L. DENOTES STRATA LOT  
 C.P. DENOTES COMMON PROPERTY  
 L.C.P. DENOTES LIMITED COMMON PROPERTY  
 C.F. DENOTES COMMON FACILITY  
 PT. DENOTES PART  
 B. DENOTES BALCONY  
 BALCONIES ARE COMMON PROPERTY AND ARE NOT INCLUDED IN SQUARE METRE (M<sup>2</sup>) AREAS  
 ALL DISTANCES ARE IN METRES.

*John Brown* B.C.L.S.  
 October 26 1988

FILED VAVAS2055 182418 2003-10-16-11.54.16.480949

PLAN OF STRATA LOTS 26-29  
 PHASE II

STRATA PLAN VR 2055

SCALE 1 : 125

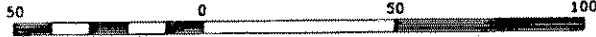

BUILDING 1  
 SECOND FLOOR

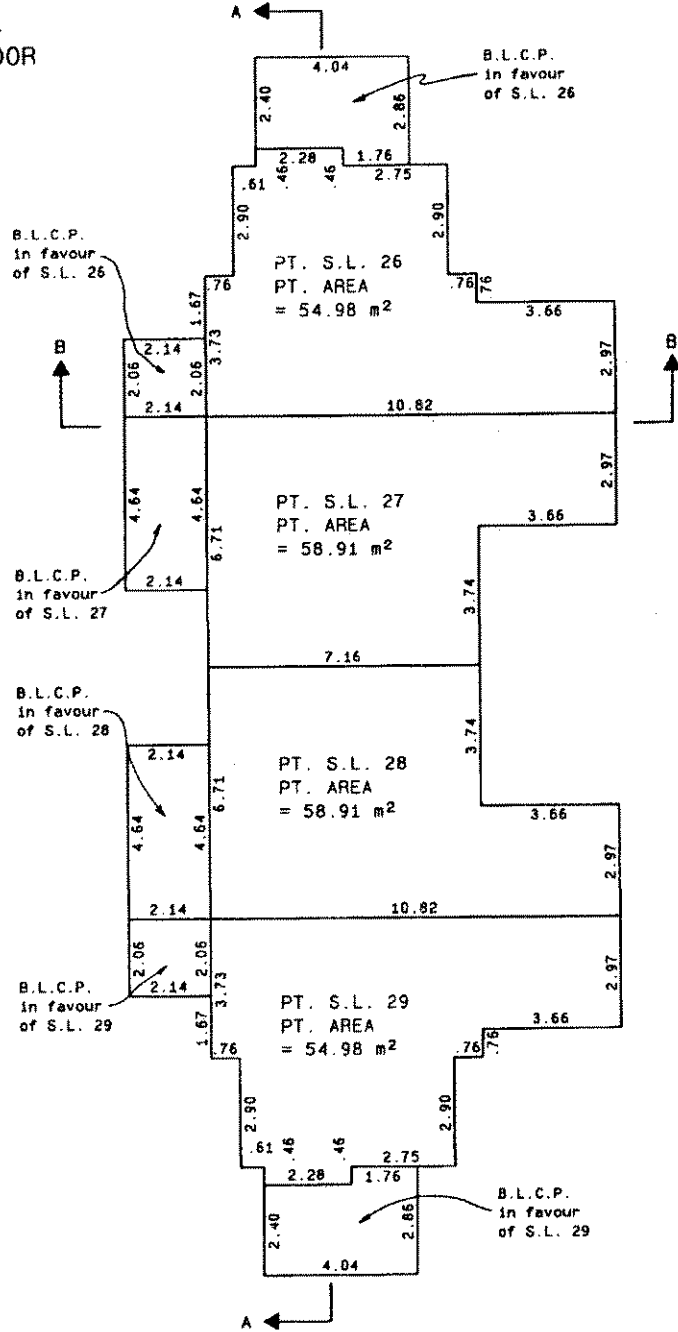

NOTE:

- S.L. DENOTES STRATA LOT
- C.P. DENOTES COMMON PROPERTY
- L.C.P. DENOTES LIMITED COMMON PROPERTY
- C.F. DENOTES COMMON FACILITY
- PT. DENOTES PART
- B. DENOTES BALCONY
- BALCONIES ARE COMMON PROPERTY AND ARE NOT INCLUDED IN SQUARE METRE (M<sup>2</sup>) AREAS
- ALL DISTANCES ARE IN METRES.

*Bruce Brown*  
 B.C.L.S.  
 October 26 1988

FILED VAVAS2055 L82418 2003-10-16-11-54-16-480949

PLAN OF STRATA LOTS 30 & 31  
 PHASE II

SHEET 6 OF 41 SHEETS

STRATA PLAN VR 2055

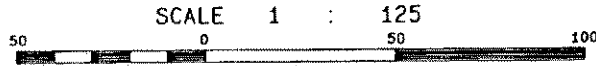

BUILDING 1  
 THIRD FLOOR



B.L.C.P.  
 in favour  
 of S.L. 30

B.L.C.P.  
 in favour  
 of S.L. 31

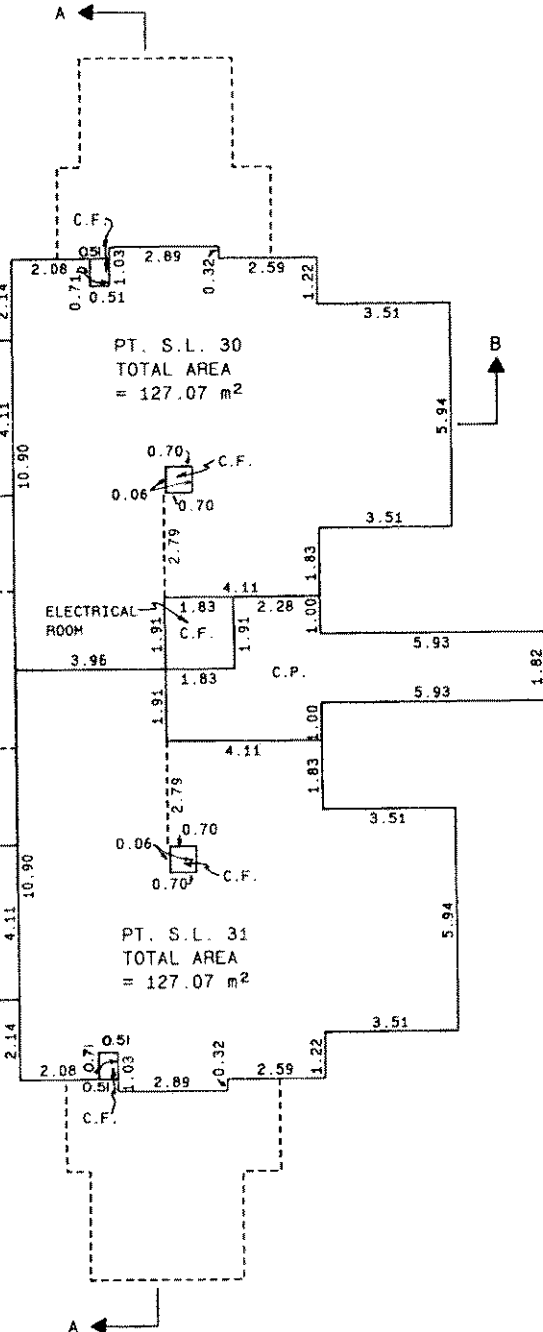

NOTE:

- S.L. DENOTES STRATA LOT
- C.P. DENOTES COMMON PROPERTY
- L.C.P. DENOTES LIMITED COMMON PROPERTY
- C.F. DENOTES COMMON FACILITY
- PT. DENOTES PART
- B. DENOTES BALCONY
- BALCONIES ARE COMMON PROPERTY AND ARE NOT INCLUDED IN SQUARE METRE (M<sup>2</sup>) AREAS
- ALL DISTANCES ARE IN METRES.

*Burnham* B.C.L.S.  
 October 26 1988

FILED VAVAS2055 L82418 2003-10-16-11-54-16-480949

FILED

PLAN OF STRATA LOTS 30 & 31  
PHASE II

STRATA PLAN VR 2055

SCALE 1 : 125



BUILDING 1  
FOURTH FLOOR

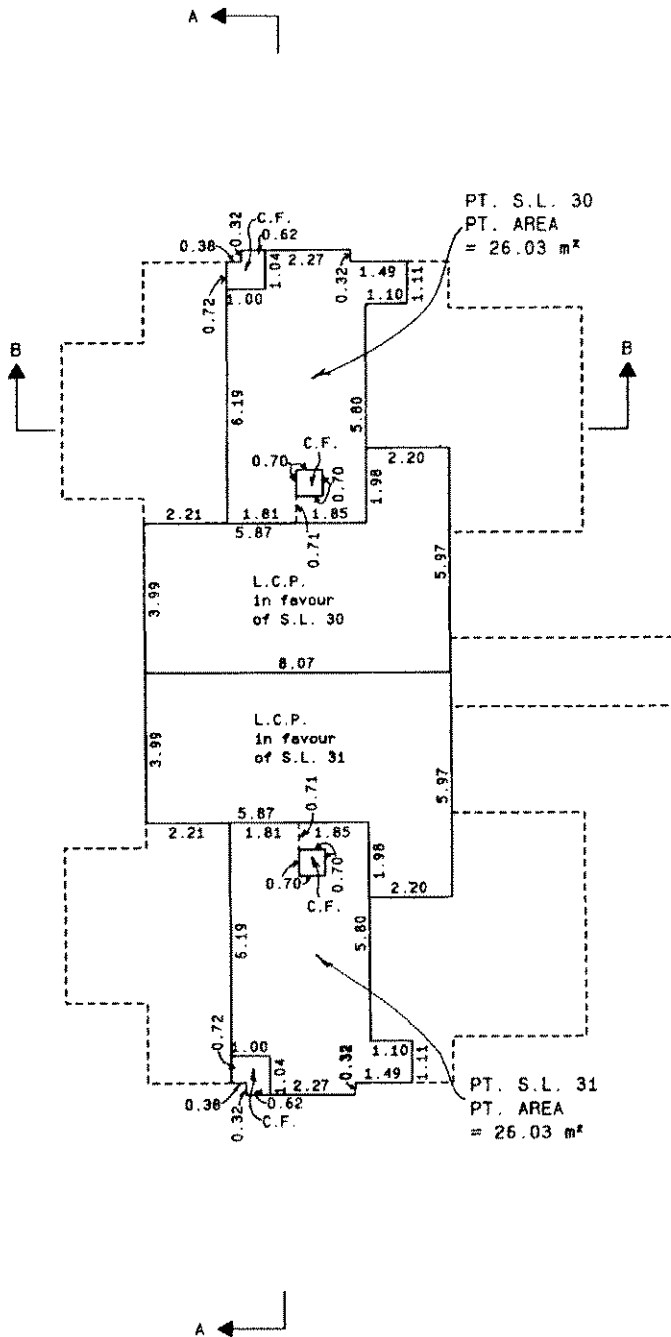

NOTE:

- S.L. DENOTES STRATA LOT
  - C.P. DENOTES COMMON PROPERTY
  - L.C.P. DENOTES LIMITED COMMON PROPERTY
  - C.F. DENOTES COMMON FACILITY
  - PT. DENOTES PART
  - B. DENOTES BALCONY
- BALCONIES ARE COMMON PROPERTY AND ARE NOT INCLUDED IN SQUARE METRE (M<sup>2</sup>) AREAS  
ALL DISTANCES ARE IN METRES.

*D. J. ...* B.C.L.S.  
October 26 1988

FILED VAVAS2055 2003-10-16-11.54.16.480949

FILED

PLAN OF STRATA LOTS 32-35  
PHASE II

STRATA PLAN VR 2055

SCALE 1 : 125



BUILDING 2  
GROUND FLOOR

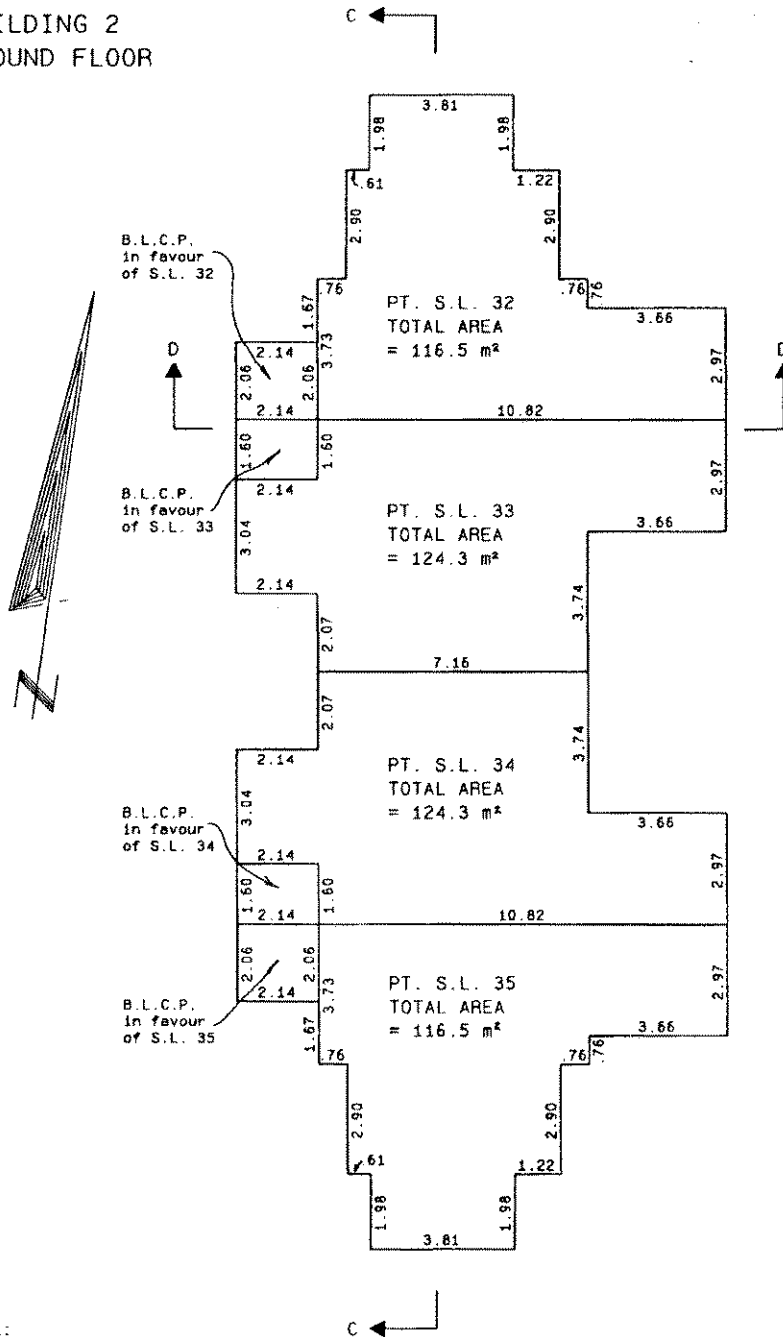

NOTE:  
S.L. DENOTES STRATA LOT  
C.P. DENOTES COMMON PROPERTY  
L.C.P. DENOTES LIMITED COMMON PROPERTY  
C.F. DENOTES COMMON FACILITY  
PT. DENOTES PART  
B. DENOTES BALCONY  
BALCONIES ARE COMMON PROPERTY AND ARE NOT INCLUDED IN SQUARE METRE (M<sup>2</sup>) AREAS  
ALL DISTANCES ARE IN METRES.

*[Signature]* B.C.L.S.  
October 26 1988

FILED VAVAS2055 L82418 2003-10-16-11.54.16.480949



PLAN OF STRATA LOTS 32-35  
PHASE II

SHEET 9 OF 41 SHEETS

STRATA PLAN VR 2055

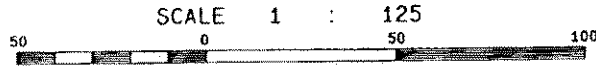

BUILDING 2  
SECOND FLOOR

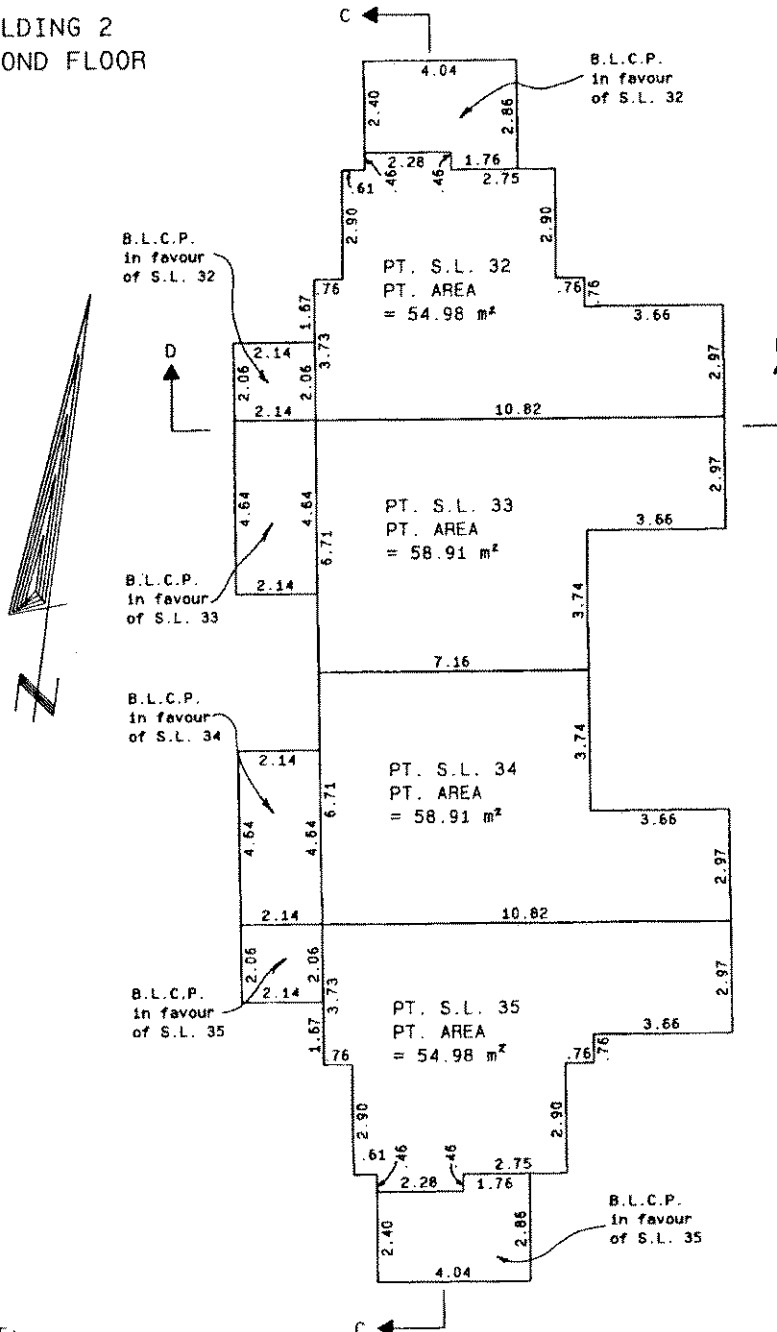

NOTE:  
S.L. DENOTES STRATA LOT  
C.P. DENOTES COMMON PROPERTY  
L.C.P. DENOTES LIMITED COMMON PROPERTY  
C.F. DENOTES COMMON FACILITY  
PT. DENOTES PART  
B. DENOTES BALCONY  
BALCONIES ARE COMMON PROPERTY AND ARE NOT INCLUDED IN SQUARE METRE (M<sup>2</sup>) AREAS  
ALL DISTANCES ARE IN METRES.

*[Signature]*  
B.C.L.S.  
October 26 1988

FILED VAVAS2055 L82418 2003-10-16-11.54.16.480949

FILED

# PLAN OF STRATA LOTS 36 & 37 PHASE II

## STRATA PLAN VR 2055

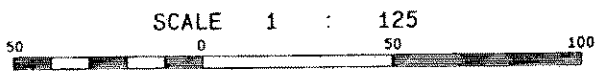

### BUILDING 2 THIRD FLOOR

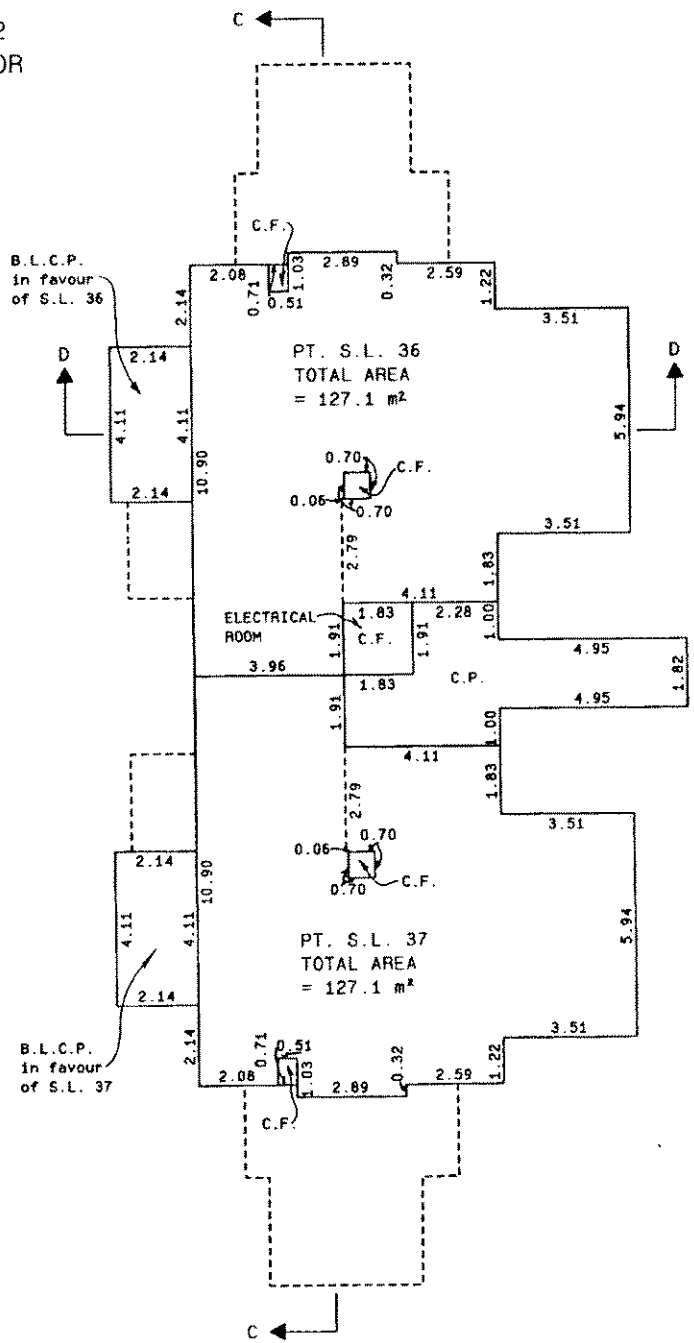

NOTE:

- S.L. DENOTES STRATA LOT
- C.P. DENOTES COMMON PROPERTY
- L.C.P. DENOTES LIMITED COMMON PROPERTY
- C.F. DENOTES COMMON FACILITY
- PT. DENOTES PART
- B. DENOTES BALCONY

BALCONIES ARE COMMON PROPERTY AND ARE NOT INCLUDED IN SQUARE METRE (M<sup>2</sup>) AREAS  
ALL DISTANCES ARE IN METRES.

*Frank Brown* B.C.L.S.  
October 26 1988

FILED VAVAS2055 182418 2003-10-16-11.54.16.480949

PLAN OF STRATA LOTS 36 & 37

PHASE II

STRATA PLAN VR 2055

SCALE 1 : 125



BUILDING 2  
FOURTH FLOOR

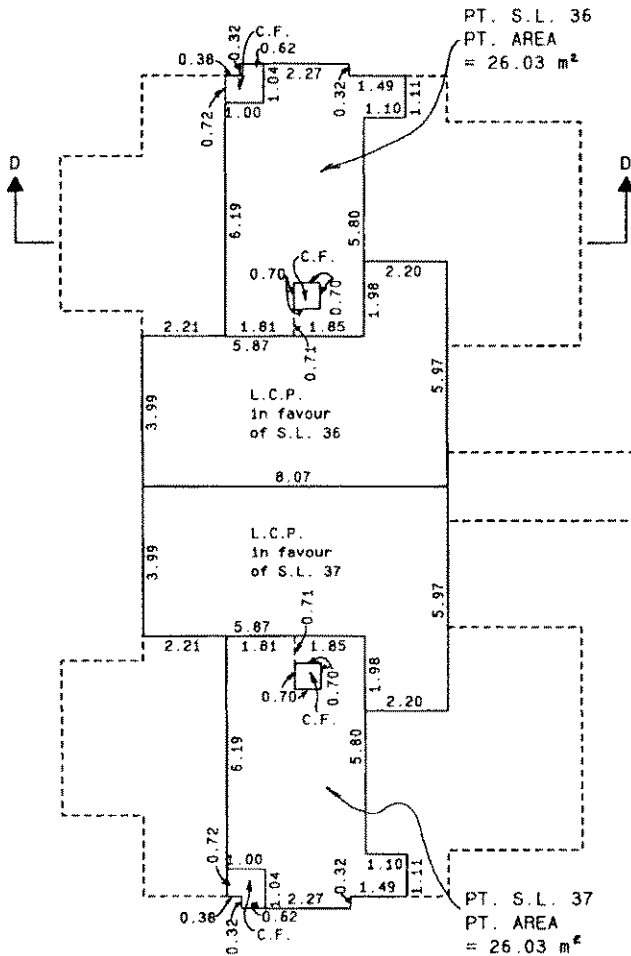

NOTE:  
 S.L. DENOTES STRATA LOT  
 C.P. DENOTES COMMON PROPERTY  
 L.C.P. DENOTES LIMITED COMMON PROPERTY  
 C.F. DENOTES COMMON FACILITY  
 PT. DENOTES PART  
 B. DENOTES BALCONY  
 BALCONIES ARE COMMON PROPERTY AND ARE NOT INCLUDED IN SQUARE METRE (M<sup>2</sup>) AREAS  
 ALL DISTANCES ARE IN METRES.

*Brian Brown* B.C.L.S.  
 October 26 1988

L82418 2003-10-16-11.54.16.480949

VAVAS2055

FILED

# PLAN OF STRATA LOTS 38 & 40 PHASE II

## STRATA PLAN VR 2055

SCALE 1 : 125



### BUILDING 5 GROUND FLOOR

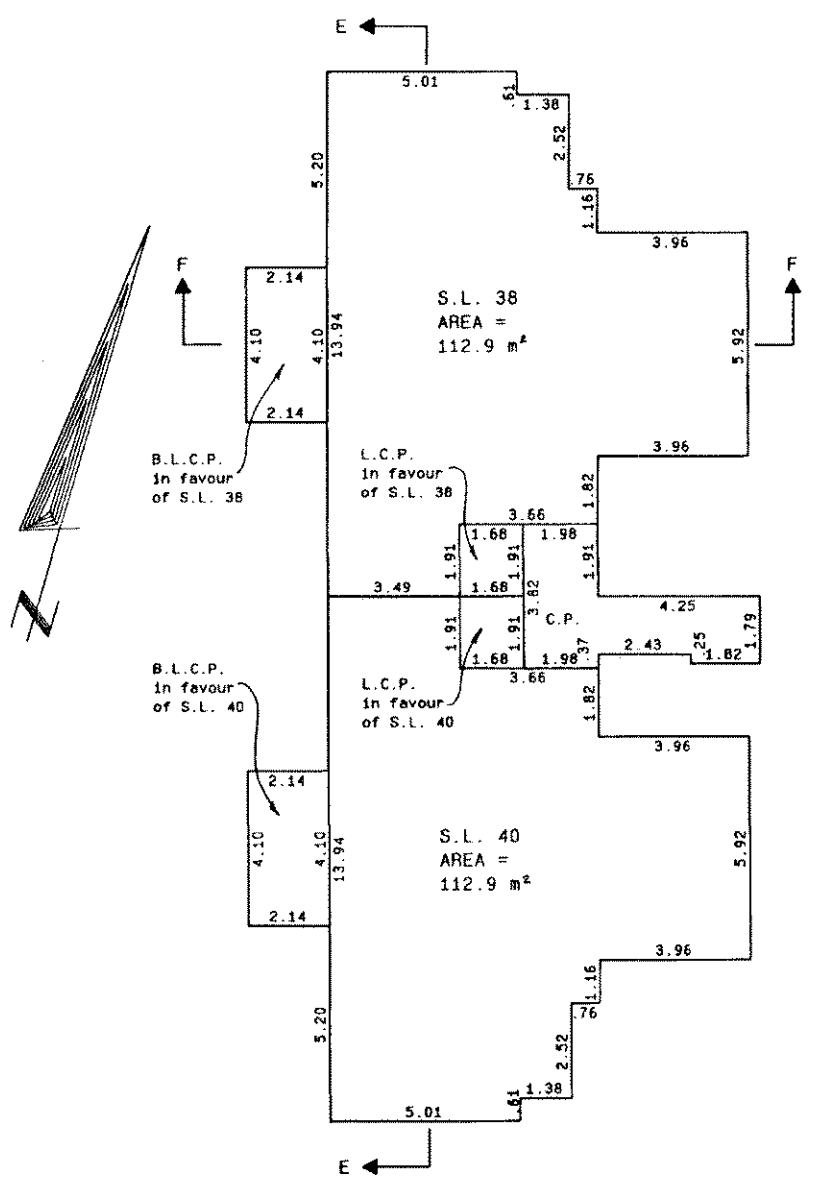

NOTE:  
 S.L. DENOTES STRATA LOT  
 C.P. DENOTES COMMON PROPERTY  
 L.C.P. DENOTES LIMITED COMMON PROPERTY  
 C.F. DENOTES COMMON FACILITY  
 PT. DENOTES PART  
 B. DENOTES BALCONY  
 BALCONIES ARE COMMON PROPERTY AND ARE NOT INCLUDED IN SQUARE METRE (M<sup>2</sup>) AREAS  
 ALL DISTANCES ARE IN METRES.

*Paul Brown* B.C.L.S.  
 October 26 1988

L82418 2003-10-16-11.54.16.480949

VAVAS2055

FILED

# PLAN OF STRATA LOTS 39 & 41 PHASE II

## STRATA PLAN VR 2055

SCALE 1 : 125

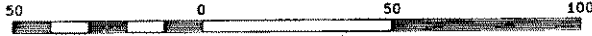

### BUILDING 5 SECOND FLOOR

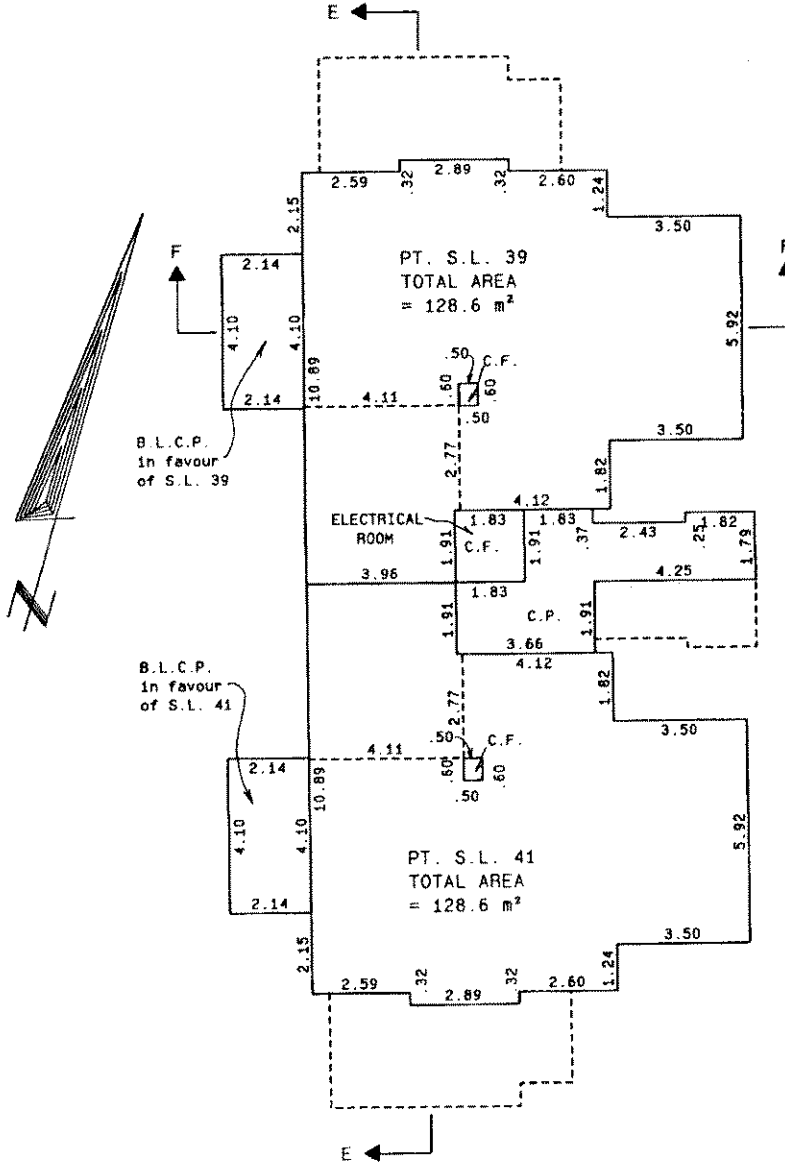

B.L.C.P.  
in favour  
of S.L. 39

B.L.C.P.  
in favour  
of S.L. 41

PT. S.L. 39  
TOTAL AREA  
= 128.6 m<sup>2</sup>

PT. S.L. 41  
TOTAL AREA  
= 128.6 m<sup>2</sup>

ELECTRICAL  
ROOM

NOTE:  
 S.L. DENOTES STRATA LOT  
 C.P. DENOTES COMMON PROPERTY  
 L.C.P. DENOTES LIMITED COMMON PROPERTY  
 C.F. DENOTES COMMON FACILITY  
 PT. DENOTES PART  
 B. DENOTES BALCONY  
 BALCONIES ARE COMMON PROPERTY AND ARE  
 NOT INCLUDED IN SQUARE METRE (M<sup>2</sup>) AREAS  
 ALL DISTANCES ARE IN METRES.

*[Signature]*  
 October 26 1988

FILED VAVAS2055 1.82418 2003-10-16-11-54-16.480949

PLAN OF STRATA LOTS 39 & 41  
PHASE II

SHEET 14 OF 41 SHEETS

STRATA PLAN VR 2055

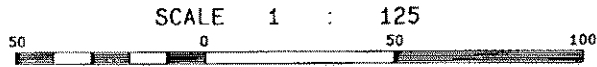

BUILDING 5  
THIRD FLOOR

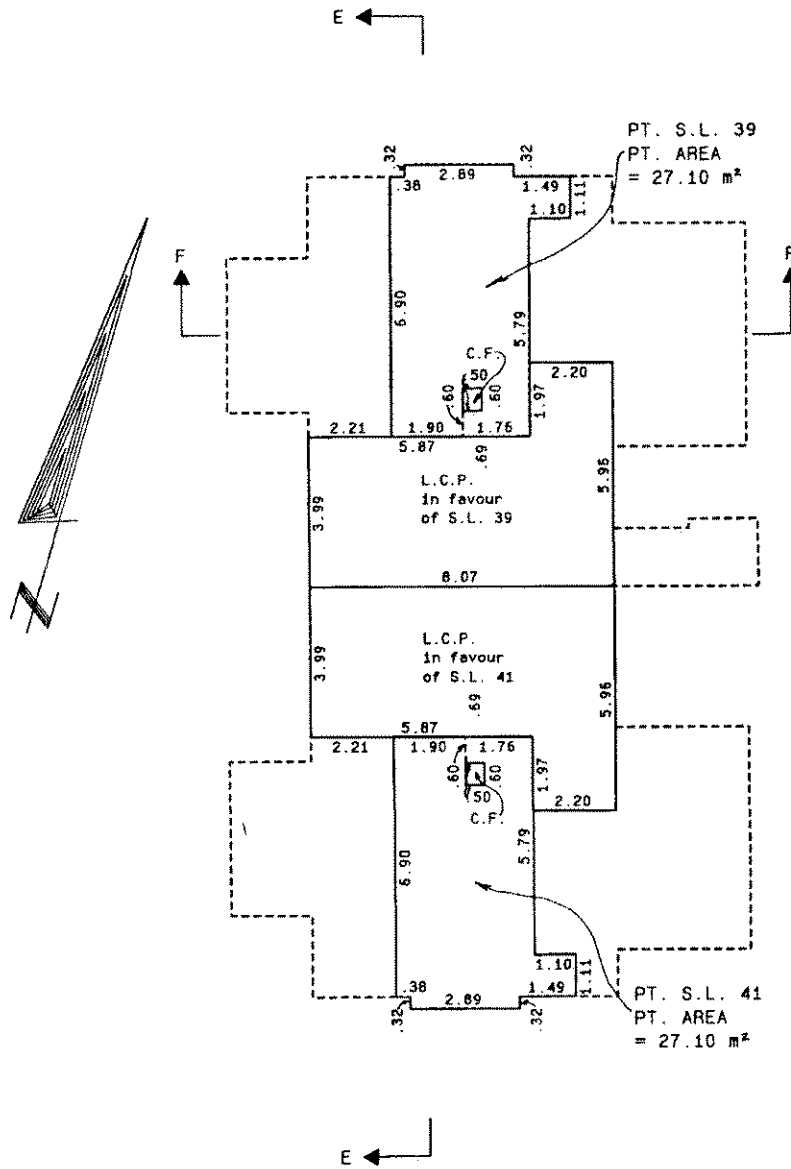

NOTE:  
S.L. DENOTES STRATA LOT  
C.P. DENOTES COMMON PROPERTY  
L.C.P. DENOTES LIMITED COMMON PROPERTY  
C.F. DENOTES COMMON FACILITY  
PT. DENOTES PART  
B. DENOTES BALCONY  
BALCONIES ARE COMMON PROPERTY AND ARE NOT INCLUDED IN SQUARE METRE (M<sup>2</sup>) AREAS  
ALL DISTANCES ARE IN METRES.

*Paul Brown* B.C.L.S.  
October 26 1988

FILED VAVAS2055 L82418 2003-10-16-11.54.16.480949

FILED

PLAN OF STRATA LOT 44  
PHASE II

SHEET 15 OF 41 SHEETS

STRATA PLAN VR 2055

SCALE 1 : 125

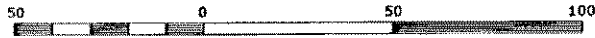

BUILDING 6  
GROUND FLOOR

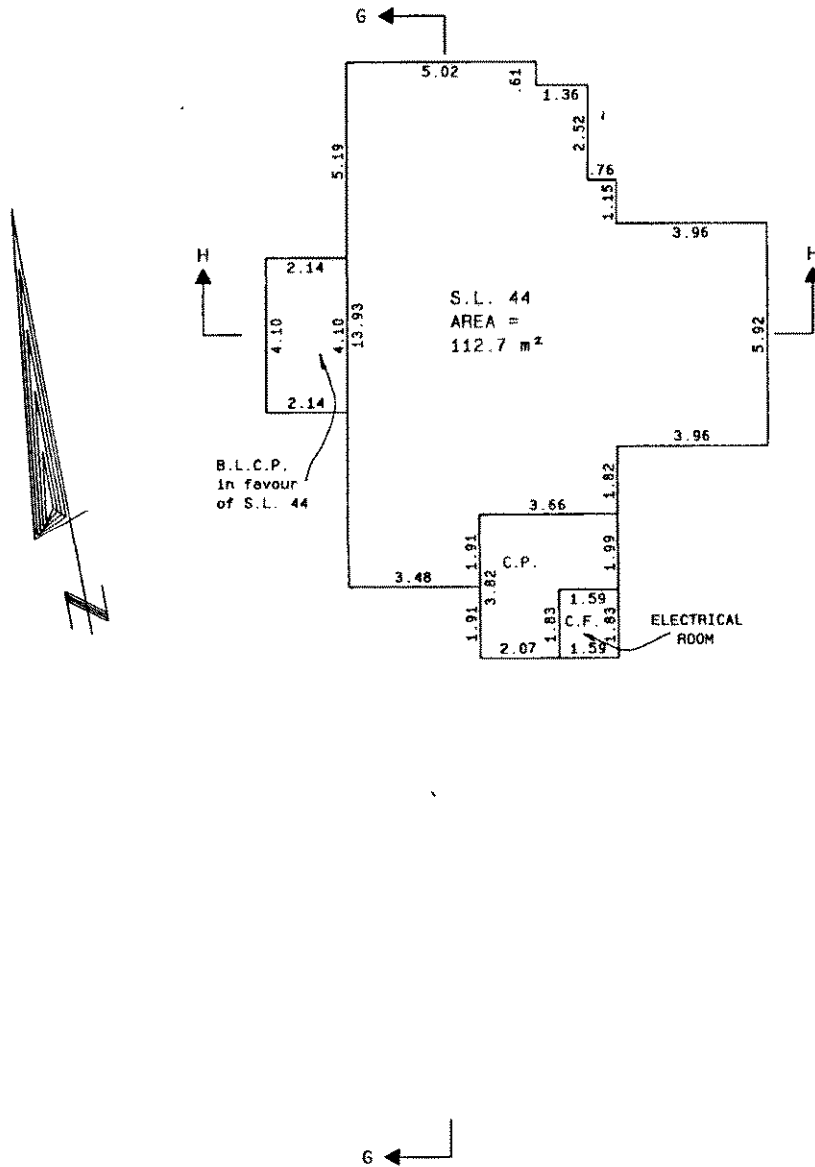

S.L. 44  
AREA =  
112.7 m<sup>2</sup>

B.L.C.P.  
in favour  
of S.L. 44

ELECTRICAL  
ROOM

NOTE:

- S.L. DENOTES STRATA LOT
- C.P. DENOTES COMMON PROPERTY
- L.C.P. DENOTES LIMITED COMMON PROPERTY
- C.F. DENOTES COMMON FACILITY
- PT. DENOTES PART
- B. DENOTES BALCONY
- BALCONIES ARE COMMON PROPERTY AND ARE NOT INCLUDED IN SQUARE METRE (M<sup>2</sup>) AREAS
- ALL DISTANCES ARE IN METRES.

*Erin Brown* B.C.L.S.  
October 26 1988

FILED VAVAS2055 L82418 2003-10-16-11.54.16.480949

PLAN OF STRATA LOTS 42 & 45  
PHASE II

SHEET 16 OF 41 SHEETS

STRATA PLAN VR 2055

SCALE 1 : 125



BUILDING 6  
SECOND FLOOR

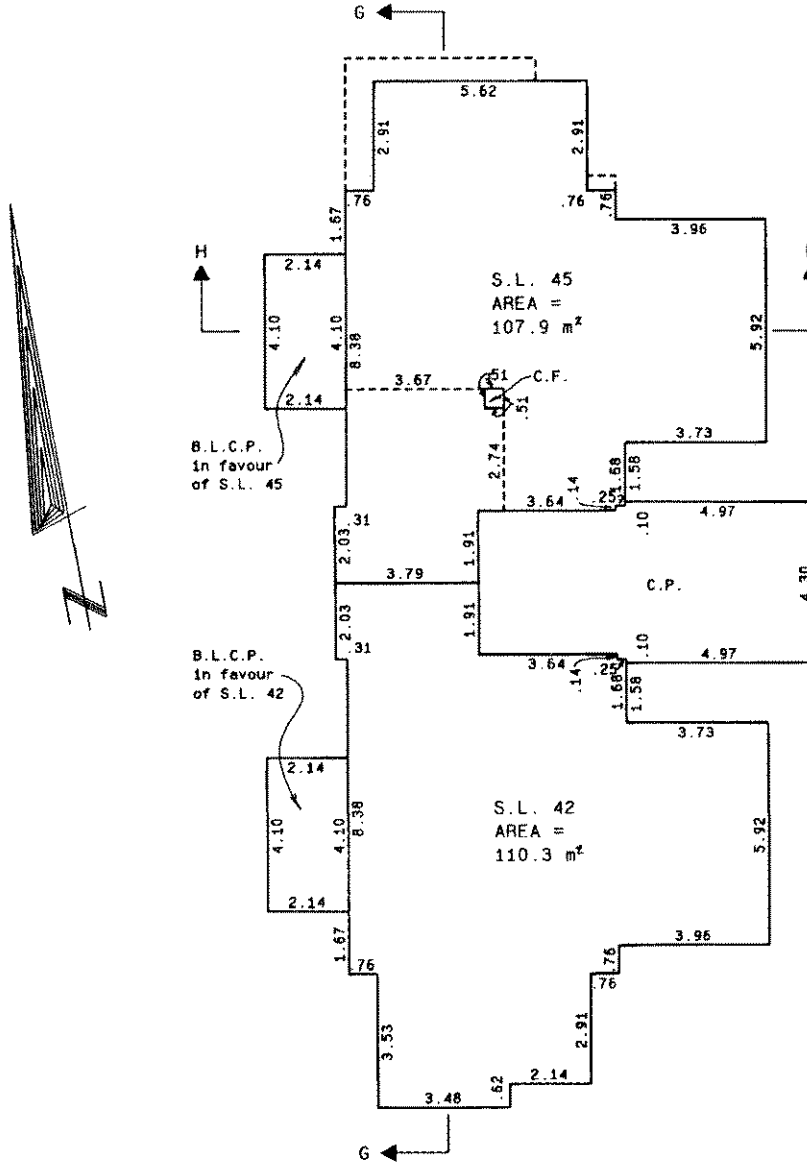

B.L.C.P.  
in favour  
of S.L. 45

B.L.C.P.  
in favour  
of S.L. 42

S.L. 45  
AREA =  
107.9 m<sup>2</sup>

S.L. 42  
AREA =  
110.3 m<sup>2</sup>

NOTE:

- S.L. DENOTES STRATA LOT
  - C.P. DENOTES COMMON PROPERTY
  - L.C.P. DENOTES LIMITED COMMON PROPERTY
  - C.F. DENOTES COMMON FACILITY
  - PT. DENOTES PART
  - B. DENOTES BALCONY
- BALCONIES ARE COMMON PROPERTY AND ARE NOT INCLUDED IN SQUARE METRE (M<sup>2</sup>) AREAS  
ALL DISTANCES ARE IN METRES.

*Paul Brown* B.C.L.S.  
October 26 1988

LB2418 2003-10-16-11.54.16.480949

VAVAS2055

FILED



PLAN OF STRATA LOTS 43 & 46  
PHASE II

STRATA PLAN VR 2055

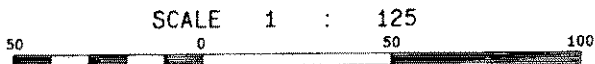

BUILDING 6  
THIRD FLOOR

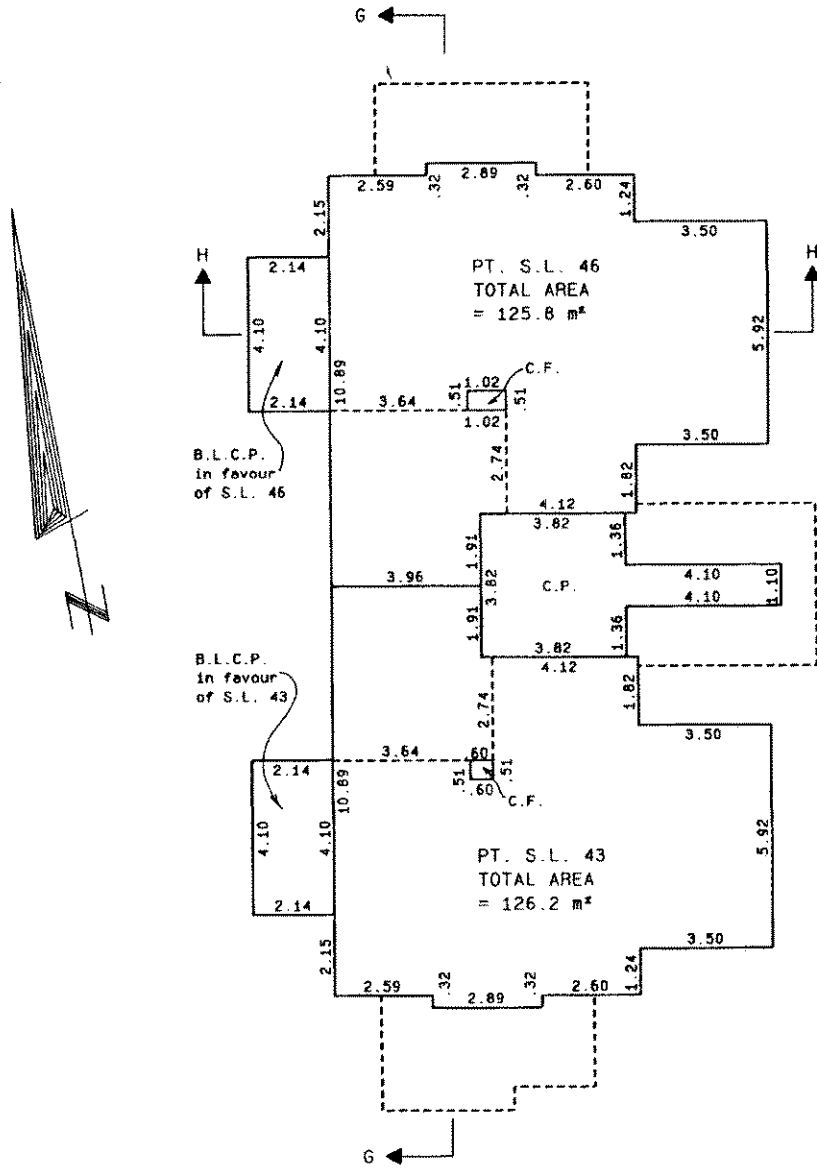

NOTE:

- S.L. DENOTES STRATA LOT
  - C.P. DENOTES COMMON PROPERTY
  - L.C.P. DENOTES LIMITED COMMON PROPERTY
  - C.F. DENOTES COMMON FACILITY
  - PT. DENOTES PART
  - B. DENOTES BALCONY
- BALCONIES ARE COMMON PROPERTY AND ARE NOT INCLUDED IN SQUARE METRE (M<sup>2</sup>) AREAS  
ALL DISTANCES ARE IN METRES.

*Paul Brown* B.C.L.S.  
October 26 1988

L82418 2003-10-16-11-54.16.480949

VAVAS2055

FILED

PLAN OF STRATA LOTS 43 & 46  
 PHASE II

SHEET 18 OF 41 SHEETS

STRATA PLAN VR 2055

SCALE 1 : 125



BUILDING 6  
 FOURTH FLOOR

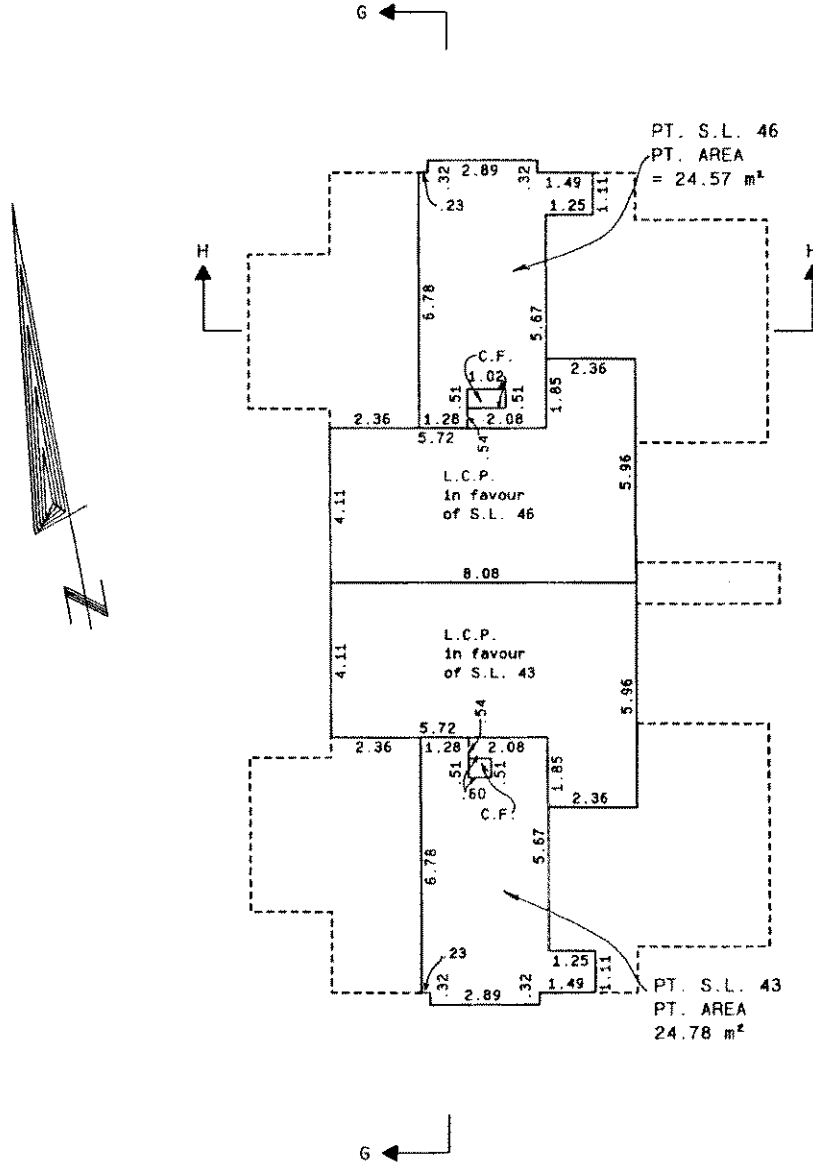

NOTE:  
 S.L. DENOTES STRATA LOT  
 C.P. DENOTES COMMON PROPERTY  
 L.C.P. DENOTES LIMITED COMMON PROPERTY  
 C.F. DENOTES COMMON FACILITY  
 PT. DENOTES PART  
 B. DENOTES BALCONY  
 BALCONIES ARE COMMON PROPERTY AND ARE NOT INCLUDED IN SQUARE METRE (M<sup>2</sup>) AREAS  
 ALL DISTANCES ARE IN METRES.

*Brian Brown* B.C.L.S.  
 October 26 1988

L82418 2003-10-16-11.54.16.488949

VAVAS2055

FILED

PLAN OF STRATA LOTS 47 & 50

PHASE II

STRATA PLAN VR 2055

SCALE 1 : 125



BUILDING 7  
GROUND FLOOR

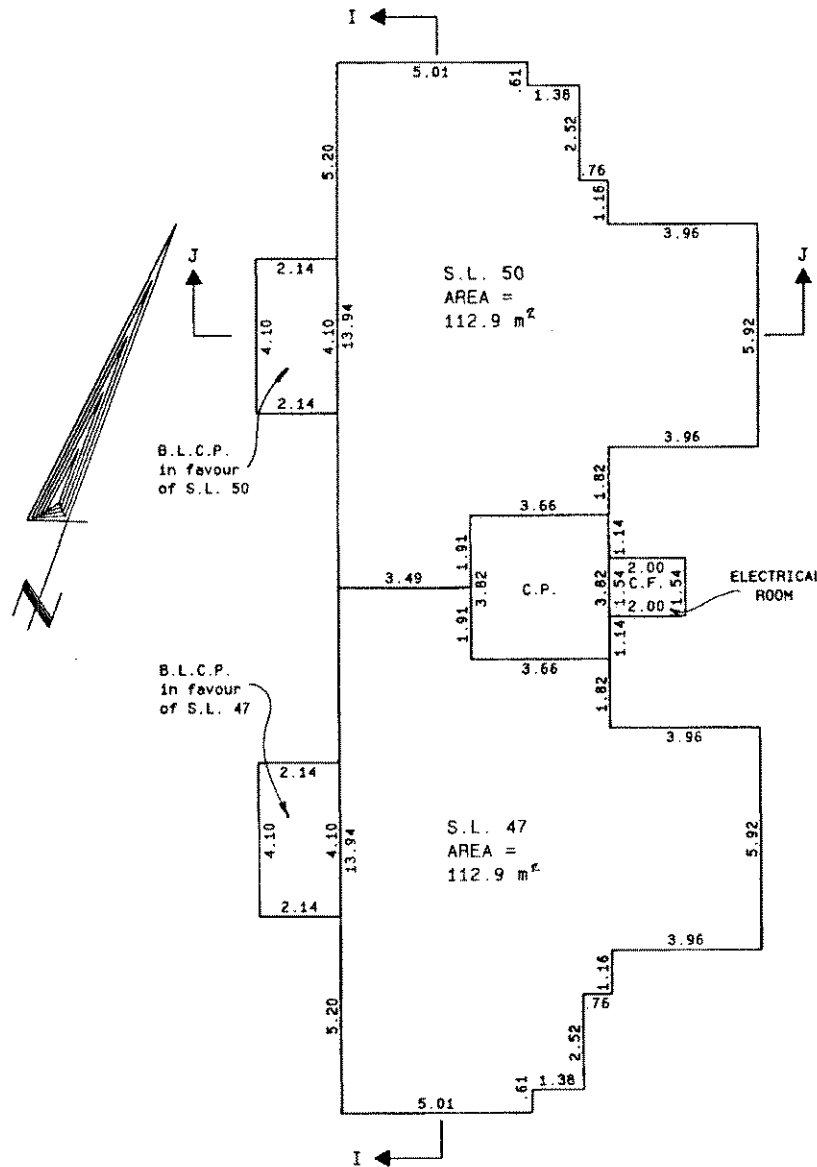

NOTE:

- S.L. DENOTES STRATA LOT
- C.P. DENOTES COMMON PROPERTY
- L.C.P. DENOTES LIMITED COMMON PROPERTY
- C.F. DENOTES COMMON FACILITY
- PT. DENOTES PART
- B. DENOTES BALCONY
- BALCONIES ARE COMMON PROPERTY AND ARE NOT INCLUDED IN SQUARE METRE (M<sup>2</sup>) AREAS
- ALL DISTANCES ARE IN METRES.

*Bruce Brown*  
October 26 1988  
B.C.L.S.



PLAN OF STRATA LOTS 49 & 52  
 PHASE II

SHEET 21 OF 41 SHEETS

STRATA PLAN VR 2055

SCALE 1 : 125



BUILDING 7  
 THIRD FLOOR

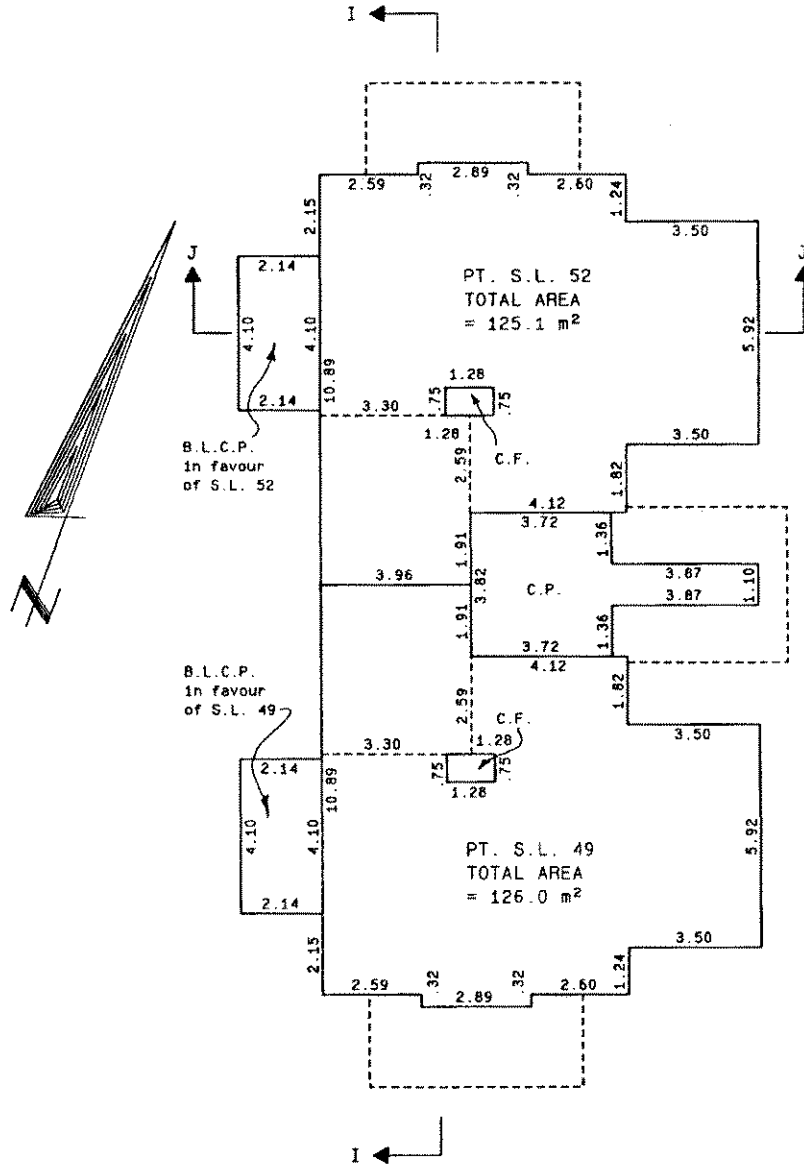

B.L.C.P.  
 in favour  
 of S.L. 52

B.L.C.P.  
 in favour  
 of S.L. 49

PT. S.L. 52  
 TOTAL AREA  
 = 125.1 m<sup>2</sup>

PT. S.L. 49  
 TOTAL AREA  
 = 126.0 m<sup>2</sup>

NOTE:  
 S.L. DENOTES STRATA LOT  
 C.P. DENOTES COMMON PROPERTY  
 L.C.P. DENOTES LIMITED COMMON PROPERTY  
 C.F. DENOTES COMMON FACILITY  
 PT. DENOTES PART  
 B. DENOTES BALCONY  
 BALCONIES ARE COMMON PROPERTY AND ARE  
 NOT INCLUDED IN SQUARE METRE (M<sup>2</sup>) AREAS  
 ALL DISTANCES ARE IN METRES.

*David Brown* B.C.L.S.  
 October 26 1988

FILED 182418 2003-10-16-11-54-16-480949

VAVAS2055

FILED

PLAN OF STRATA LOTS 49 & 52  
 PHASE II

SHEET 22 OF 41 SHEETS

STRATA PLAN VR 2055

SCALE 1 : 125



BUILDING 7  
 FOURTH FLOOR

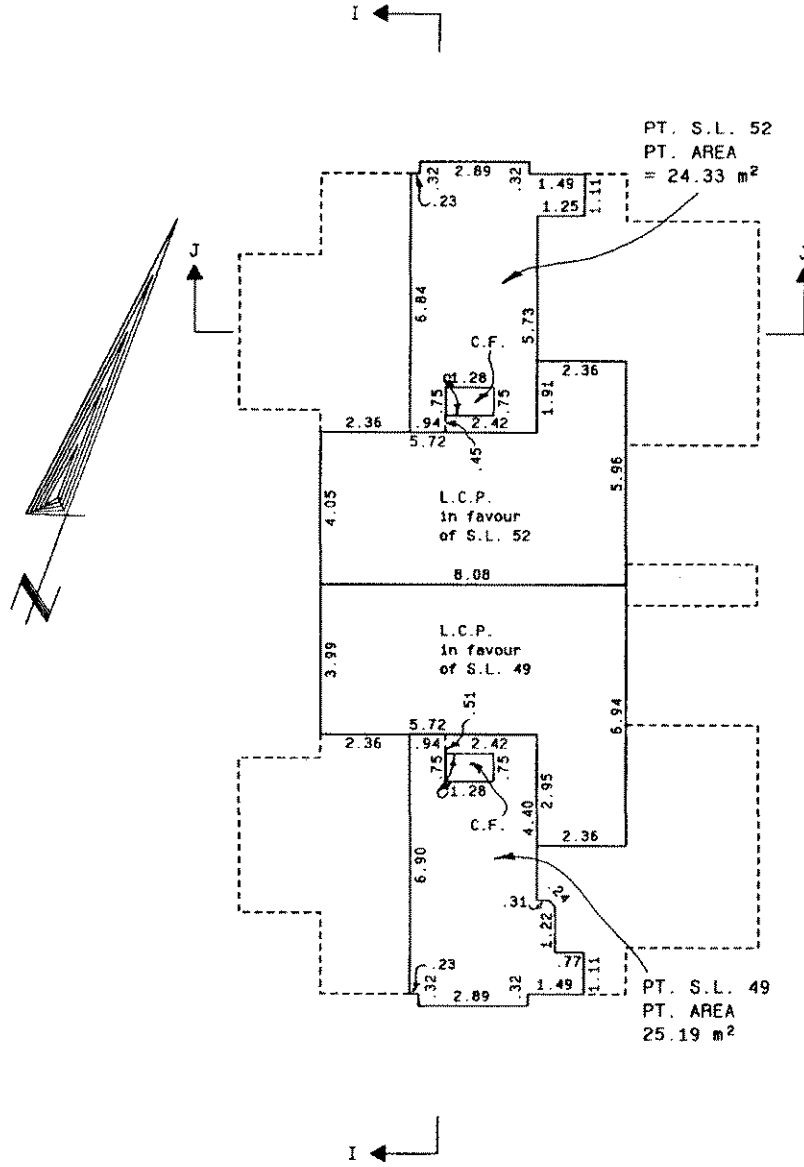

PT. S.L. 52  
 PT. AREA  
 = 24.33 m<sup>2</sup>

PT. S.L. 49  
 PT. AREA  
 25.19 m<sup>2</sup>

NOTE:  
 S.L. DENOTES STRATA LOT  
 C.P. DENOTES COMMON PROPERTY  
 L.C.P. DENOTES LIMITED COMMON PROPERTY  
 C.F. DENOTES COMMON FACILITY  
 PT. DENOTES PART  
 B. DENOTES BALCONY  
 BALCONIES ARE COMMON PROPERTY AND ARE  
 NOT INCLUDED IN SQUARE METRE (M<sup>2</sup>) AREAS  
 ALL DISTANCES ARE IN METRES.

*Paul Brown* B.C.L.S.  
 October 26 1988

FILED VAVAS2055 182418 2003-10-16-11.54.16.480949

PLAN OF STRATA LOT 54  
AND PARKING

STRATA PLAN VR 2055

PHASE II

SCALE 1 : 125



BUILDING 11  
GROUND FLOOR

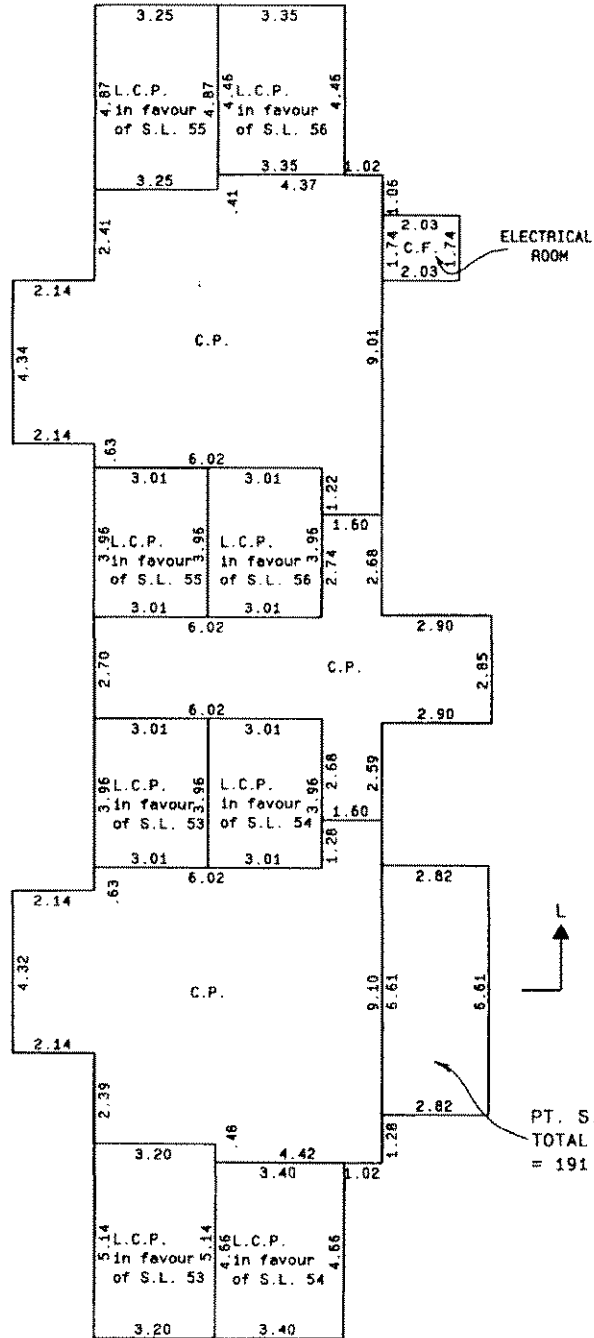

PT. S.L. 54  
TOTAL AREA  
= 191.4 m<sup>2</sup>

NOTE:  
S.L. DENOTES STRATA LOT  
C.P. DENOTES COMMON PROPERTY  
L.C.P. DENOTES LIMITED COMMON PROPERTY  
C.F. DENOTES COMMON FACILITY  
PT. DENOTES PART  
B. DENOTES BALCONY  
BALCONIES ARE COMMON PROPERTY AND ARE NOT INCLUDED IN SQUARE METRE (M<sup>2</sup>) AREAS  
ALL DISTANCES ARE IN METRES.

*Paul Brown*  
October 26 1988  
B.C.L.S.

1.82418 2003-10-16-11.54.16.480949

VAVAS2055

FILED

# PLAN OF STRATA LOTS 53-55 PHASE II

## STRATA PLAN VR 2055

SCALE 1 : 125

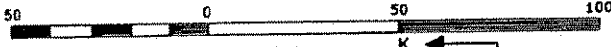

BUILDING 11  
SECOND FLOOR

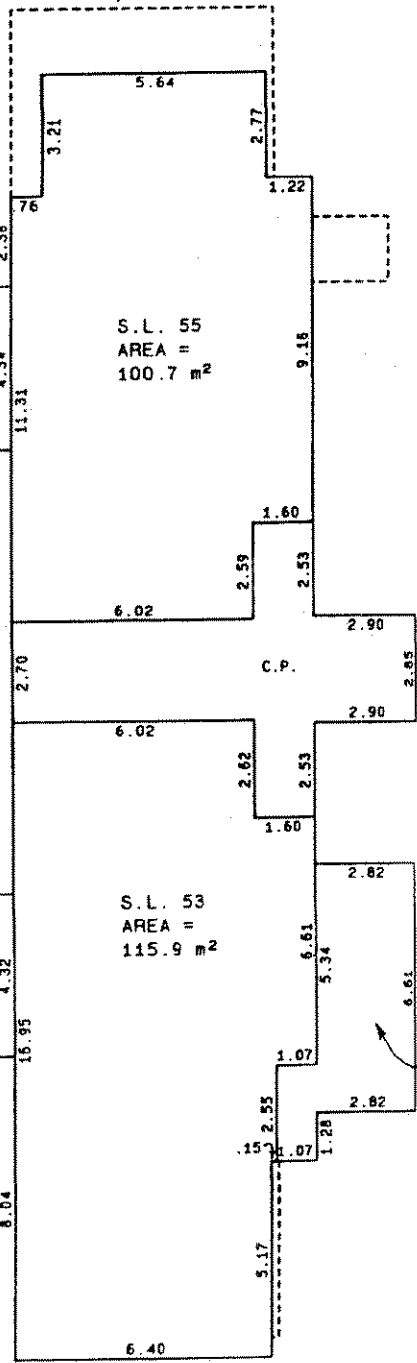
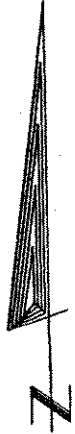

S.L. 55  
AREA =  
100.7 m<sup>2</sup>

S.L. 53  
AREA =  
115.9 m<sup>2</sup>

PT. S.L. 54  
PT. AREA  
= 21.37 m<sup>2</sup>

B.L.C.P.  
in favour  
of S.L. 55

B.L.C.P.  
in favour  
of S.L. 53

NOTE:  
S.L. DENOTES STRATA LOT  
C.P. DENOTES COMMON PROPERTY  
L.C.P. DENOTES LIMITED COMMON PROPERTY  
C.F. DENOTES COMMON FACILITY  
PT. DENOTES PART  
B. DENOTES BALCONY  
BALCONIES ARE COMMON PROPERTY AND ARE  
NOT INCLUDED IN SQUARE METRE (M<sup>2</sup>) AREAS  
ALL DISTANCES ARE IN METRES.

*Barry Brown*  
B.C.L.S.  
October 26 1988

FILED VAVAS2055 182418 2003-10-16-11.54.16.480949





PLAN OF STRATA LOTS 54 & 56  
PHASE II

SHEET 26 OF 41 SHEETS

STRATA PLAN VR 2055

SCALE 1 : 125



BUILDING 11  
FOURTH FLOOR

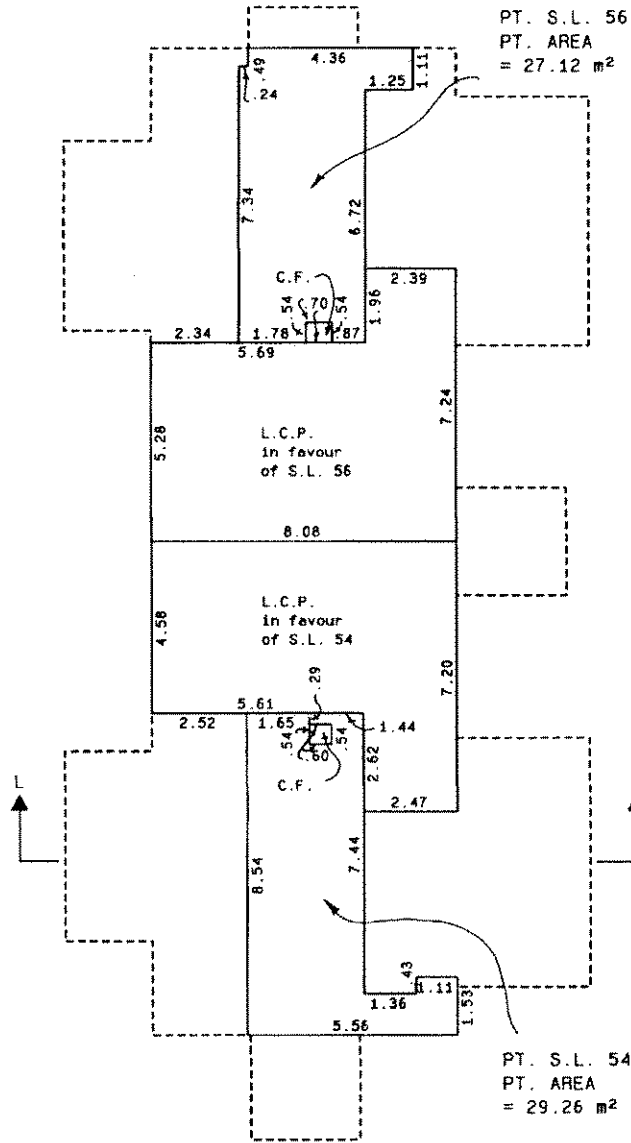
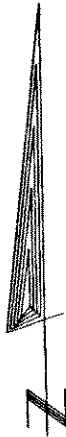

NOTE:

- S.L. DENOTES STRATA LOT
  - C.P. DENOTES COMMON PROPERTY
  - L.C.P. DENOTES LIMITED COMMON PROPERTY
  - C.F. DENOTES COMMON FACILITY
  - PT. DENOTES PART
  - B. DENOTES BALCONY
- BALCONIES ARE COMMON PROPERTY AND ARE NOT INCLUDED IN SQUARE METRE (M<sup>2</sup>) AREAS  
ALL DISTANCES ARE IN METRES.

*Brian Brown* B.C.L.S.  
October 26 1988

FILED VAVAS2055 L82418 2003-10-16-11.54.16.480849

CROSS - SECTIONS  
PHASE II

STRATA PLAN VR 2055

SCALE 1 : 125

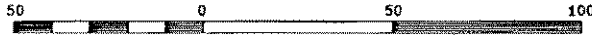

BUILDING 1  
CROSS-SECTION 'A-A'

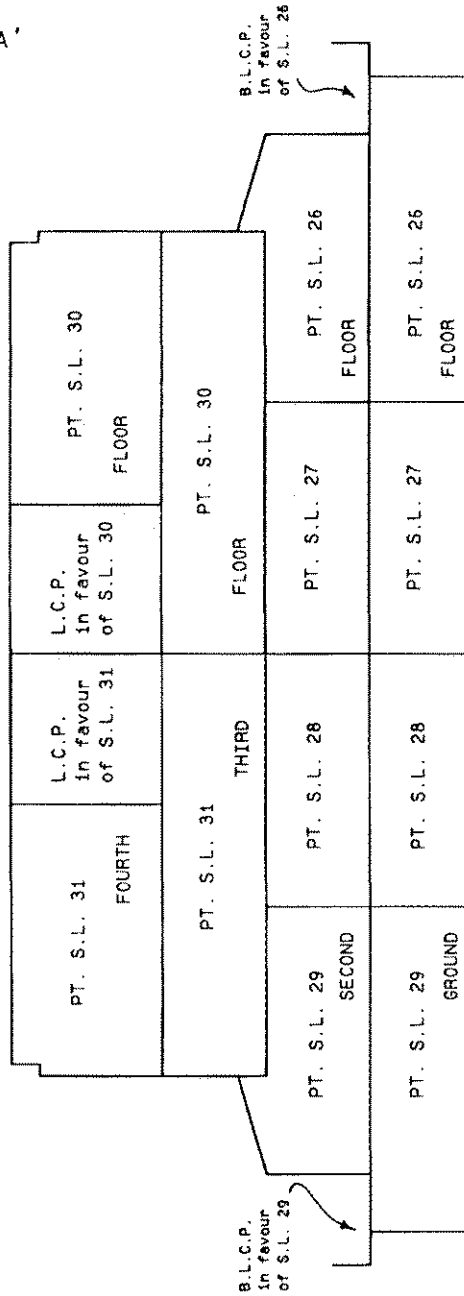

NOTE:  
 S.L. DENOTES STRATA LOT  
 C.P. DENOTES COMMON PROPERTY  
 L.C.P. DENOTES LIMITED COMMON PROPERTY  
 C.F. DENOTES COMMON FACILITY  
 PT. DENOTES PART  
 B. DENOTES BALCONY  
 BALCONIES ARE COMMON PROPERTY AND ARE NOT INCLUDED IN SQUARE METRE (M<sup>2</sup>) AREAS  
 ALL DISTANCES ARE IN METRES.

*Randy Brown* B.C.L.S.  
 October 26 1988

FILED VAVAS2055 L82418 2003-10-16-11.54.16.480949

CROSS - SECTIONS  
PHASE II

STRATA PLAN VR 2055

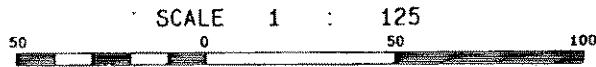

BUILDING 1  
CROSS-SECTION 'B-B'

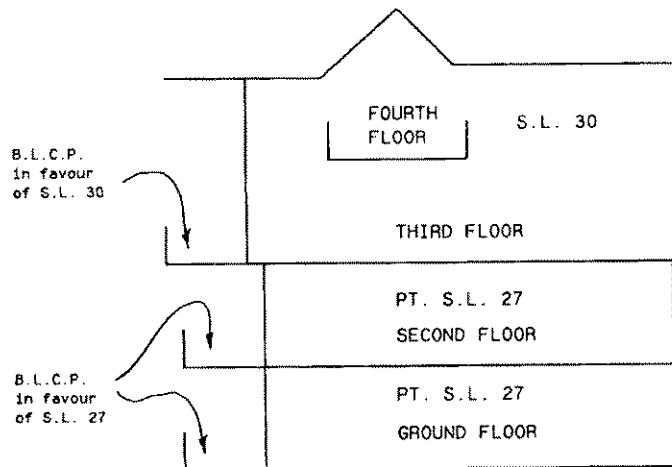

NOTE:  
S.L. DENOTES STRATA LOT  
C.P. DENOTES COMMON PROPERTY  
L.C.P. DENOTES LIMITED COMMON PROPERTY  
C.F. DENOTES COMMON FACILITY  
PT. DENOTES PART  
B. DENOTES BALCONY  
BALCONIES ARE COMMON PROPERTY AND ARE NOT INCLUDED IN SQUARE METRE (M<sup>2</sup>) AREAS  
ALL DISTANCES ARE IN METRES.

*[Signature]* B.C.L.S.  
October 26 1988

FILED VAVAS2055 L82418 2003-10-16-11.54.16.480949

FILED

CROSS - SECTIONS  
PHASE II

STRATA PLAN VR 2055

SCALE 1 : 125



BUILDING 2  
CROSS-SECTION 'C-C'

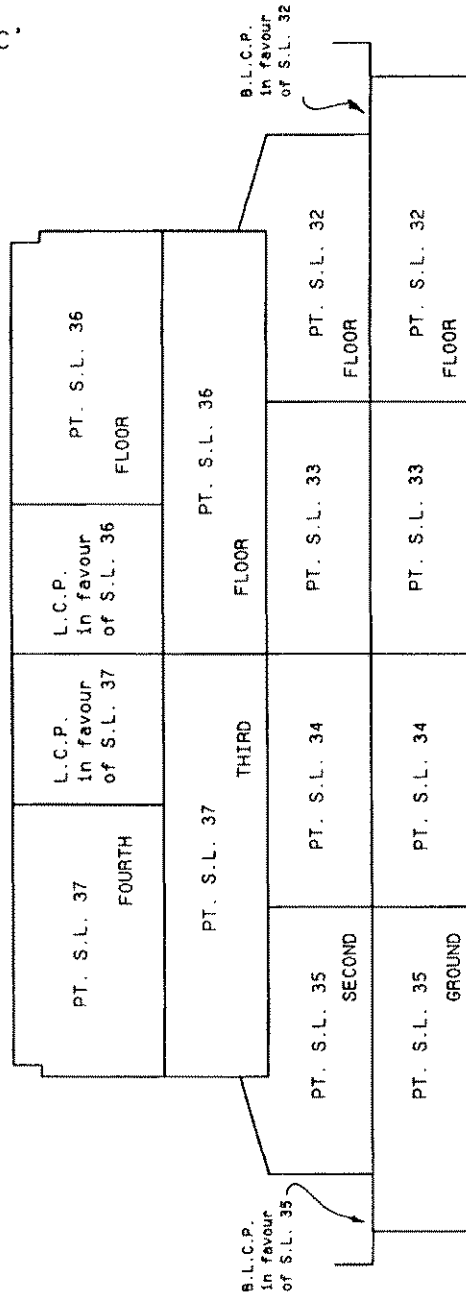

NOTE:  
S.L. DENOTES STRATA LOT  
C.P. DENOTES COMMON PROPERTY  
L.C.P. DENOTES LIMITED COMMON PROPERTY  
C.F. DENOTES COMMON FACILITY  
PT. DENOTES PART  
B. DENOTES BALCONY  
BALCONIES ARE COMMON PROPERTY AND ARE NOT INCLUDED IN SQUARE METRE (M<sup>2</sup>) AREAS  
ALL DISTANCES ARE IN METRES.

*Paul Brown* B.C.L.S.  
October 26 1988

CROSS - SECTIONS  
PHASE II

SHEET 30 OF 41 SHEETS

STRATA PLAN VR 2055

SCALE 1 : 125

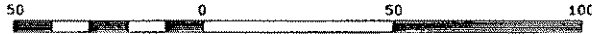

BUILDING 2  
CROSS-SECTION 'D-D'

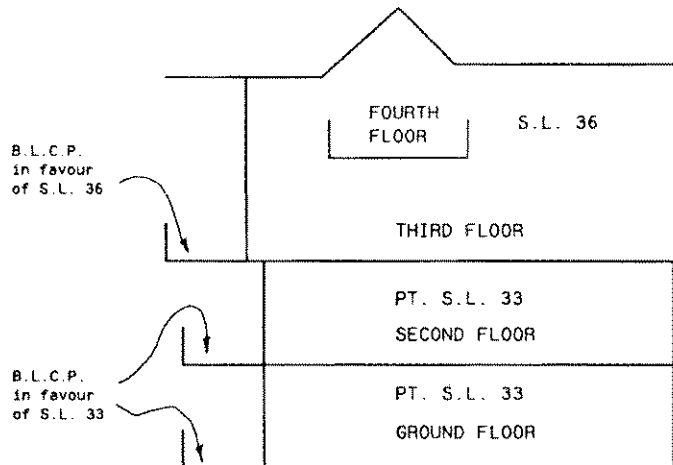

NOTE:  
S.L. DENOTES STRATA LOT  
C.P. DENOTES COMMON PROPERTY  
L.C.P. DENOTES LIMITED COMMON PROPERTY  
C.F. DENOTES COMMON FACILITY  
PT. DENOTES PART  
B. DENOTES BALCONY  
BALCONIES ARE COMMON PROPERTY AND ARE NOT INCLUDED IN SQUARE METRE (M<sup>2</sup>) AREAS  
ALL DISTANCES ARE IN METRES.

*Brian Brown* B.C.L.S.  
October 26 1988

L82418 2003-10-16-11-54.16.480949

VAVAS2055

FILED

CROSS - SECTIONS  
PHASE II

STRATA PLAN VR 2055

SCALE 1 : 125



BUILDING 5  
CROSS-SECTION 'E-E'

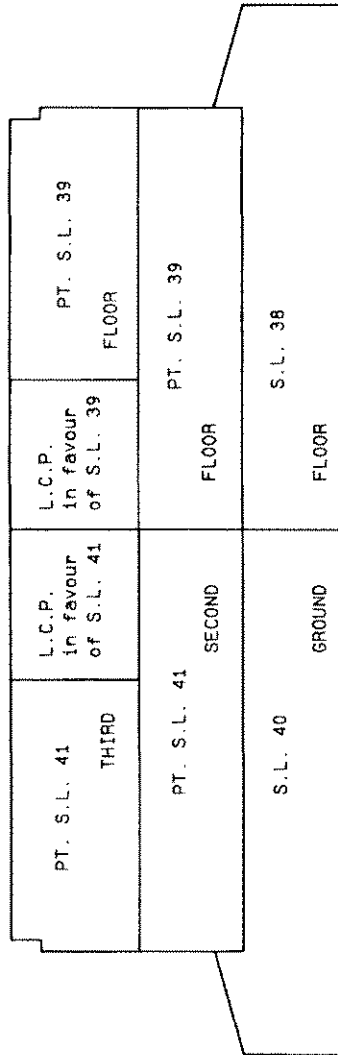

NOTE:

- S.L. DENOTES STRATA LOT
  - C.P. DENOTES COMMON PROPERTY
  - L.C.P. DENOTES LIMITED COMMON PROPERTY
  - C.F. DENOTES COMMON FACILITY
  - PT. DENOTES PART
  - B. DENOTES BALCONY
- BALCONIES ARE COMMON PROPERTY AND ARE NOT INCLUDED IN SQUARE METRE (M<sup>2</sup>) AREAS  
ALL DISTANCES ARE IN METRES.

*Ronald Brown* B.C.L.S.  
October 26 1988

FILED VAVAS2055 2003-10-16-11-54.16.480949

FILED

CROSS - SECTIONS  
PHASE II

SHEET 32 OF 41 SHEETS

STRATA PLAN VR 2055

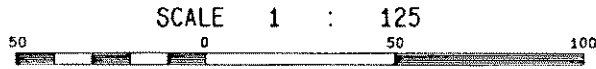

BUILDING 5  
CROSS-SECTION 'F-F'

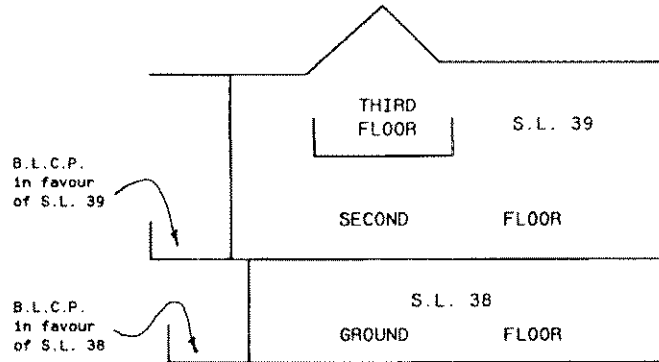

NOTE:

- S.L. DENOTES STRATA LOT
  - C.P. DENOTES COMMON PROPERTY
  - L.C.P. DENOTES LIMITED COMMON PROPERTY
  - C.F. DENOTES COMMON FACILITY
  - PT. DENOTES PART
  - B. DENOTES BALCONY
- BALCONIES ARE COMMON PROPERTY AND ARE NOT INCLUDED IN SQUARE METRE (M<sup>2</sup>) AREAS  
ALL DISTANCES ARE IN METRES.

*Brian Brown* B.C.L.S.  
October 26 1988

182418 2003-10-16-11.54.16.480949

VAVAS2055

FILED



CROSS - SECTIONS  
 PHASE II

STRATA PLAN VR 2055

SCALE 1 : 125



BUILDING 6  
 CROSS-SECTION 'G-G'

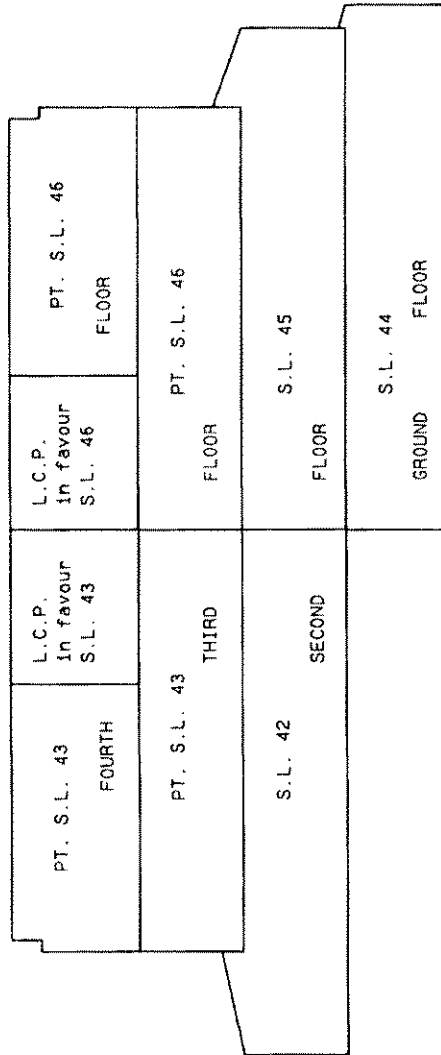

NOTE:  
 S.L. DENOTES STRATA LOT  
 C.P. DENOTES COMMON PROPERTY  
 L.C.P. DENOTES LIMITED COMMON PROPERTY  
 C.F. DENOTES COMMON FACILITY  
 PT. DENOTES PART  
 B. DENOTES BALCONY  
 BALCONIES ARE COMMON PROPERTY AND ARE NOT INCLUDED IN SQUARE METRE (M<sup>2</sup>) AREAS  
 ALL DISTANCES ARE IN METRES.

*Paul Brown* B.C.L.S.  
 October 26 1988

FILED 182418 2003-10-16-11.54.16.480949

VAVAS2055

FILED

# CROSS - SECTIONS PHASE II

## STRATA PLAN VR 2055

SCALE 1 : 125



### BUILDING 6 CROSS-SECTION 'H-H'

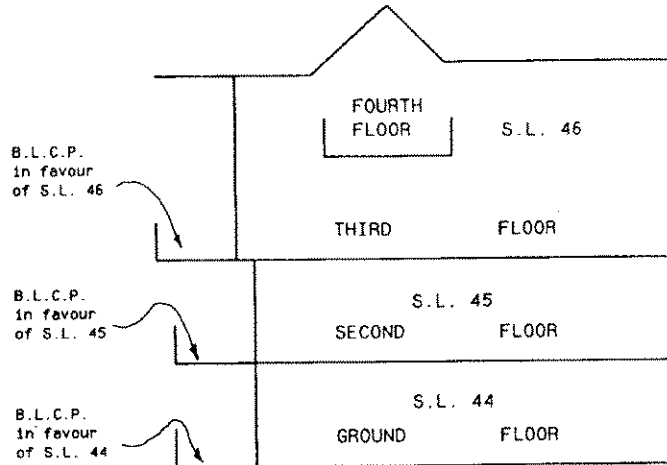

**NOTE:**

- S.L. DENOTES STRATA LOT
  - C.P. DENOTES COMMON PROPERTY
  - L.C.P. DENOTES LIMITED COMMON PROPERTY
  - C.F. DENOTES COMMON FACILITY
  - PT. DENOTES PART
  - B. DENOTES BALCONY
- BALCONIES ARE COMMON PROPERTY AND ARE NOT INCLUDED IN SQUARE METRE (M<sup>2</sup>) AREAS  
ALL DISTANCES ARE IN METRES.

*Brian Brown* B.C.L.S.  
October 26 1988

FILED VAVAS2055 LB2418 2003-10-16-11.54.16.480949

CROSS - SECTIONS  
PHASE II

STRATA PLAN VR 2055

SCALE 1 : 125



BUILDING 7  
CROSS-SECTION 'I-I'

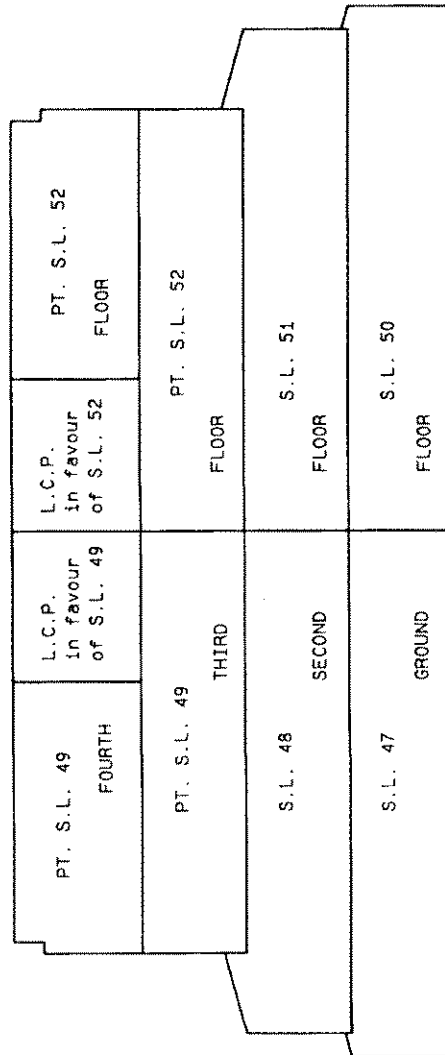

NOTE:  
 S.L. DENOTES STRATA LOT  
 C.P. DENOTES COMMON PROPERTY  
 L.C.P. DENOTES LIMITED COMMON PROPERTY  
 C.F. DENOTES COMMON FACILITY  
 PT. DENOTES PART  
 B. DENOTES BALCONY  
 BALCONIES ARE COMMON PROPERTY AND ARE NOT INCLUDED IN SQUARE METRE (M<sup>2</sup>) AREAS  
 ALL DISTANCES ARE IN METRES.

*Brian Brown* B.C.L.S.  
 October 26 1988

L82418 2003-10-16-11.54.16.480949

VAVAS2055

FILED

CROSS - SECTIONS  
PHASE II

STRATA PLAN VR 2055

SCALE 1 : 125

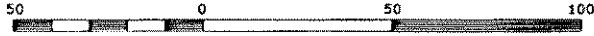

BUILDING 7  
CROSS-SECTION 'J-J'

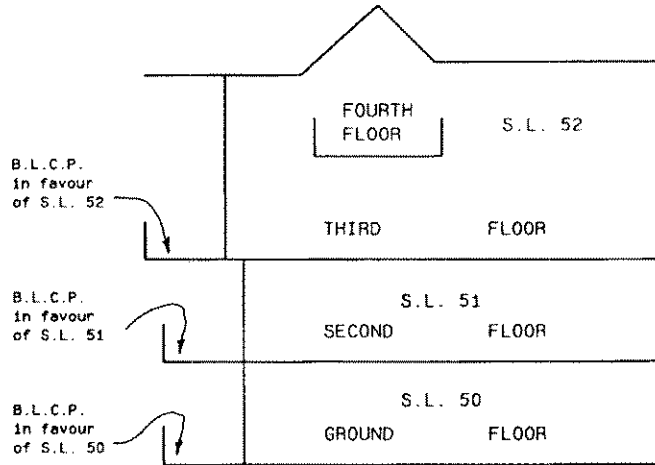

NOTE:  
S.L. DENOTES STRATA LOT  
C.P. DENOTES COMMON PROPERTY  
L.C.P. DENOTES LIMITED COMMON PROPERTY  
C.F. DENOTES COMMON FACILITY  
PT. DENOTES PART  
B. DENOTES BALCONY  
BALCONIES ARE COMMON PROPERTY AND ARE NOT INCLUDED IN SQUARE METRE (M<sup>2</sup>) AREAS  
ALL DISTANCES ARE IN METRES.

*Brian Brown* B.C.L.S.  
October 26 1988

CROSS - SECTIONS

PHASE II

STRATA PLAN VR 2055

SCALE 1 : 125

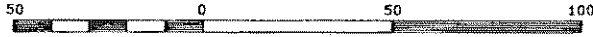

BUILDING 11  
CROSS-SECTION 'K-K'

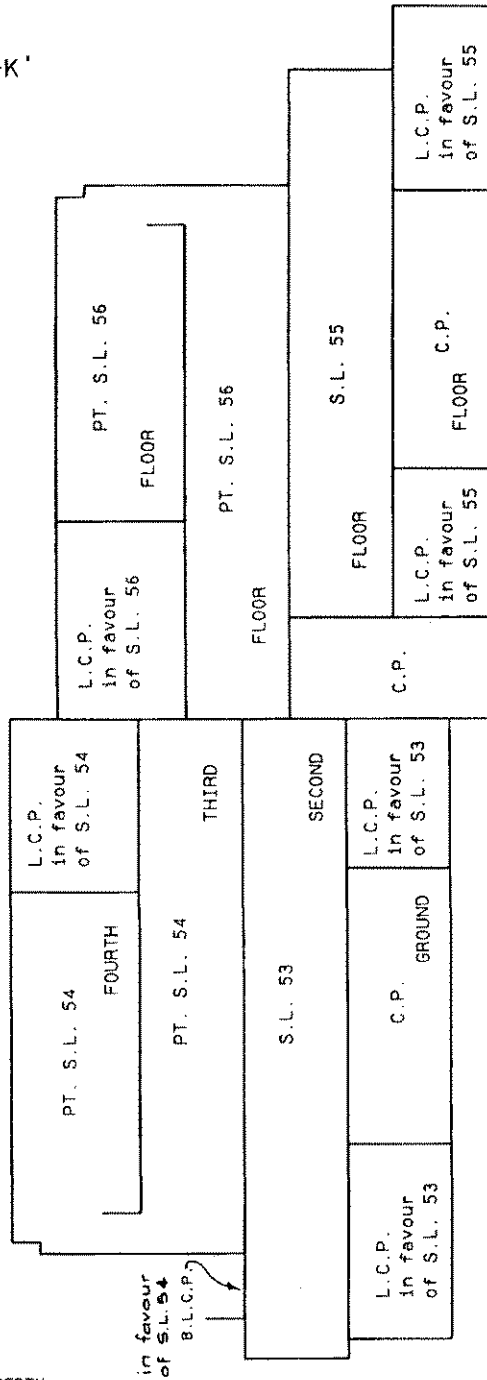

NOTE:  
 S.L. DENOTES STRATA LOT  
 C.P. DENOTES COMMON PROPERTY  
 L.C.P. DENOTES LIMITED COMMON PROPERTY  
 C.F. DENOTES COMMON FACILITY  
 PT. DENOTES PART  
 B. DENOTES BALCONY  
 BALCONIES ARE COMMON PROPERTY AND ARE NOT INCLUDED IN SQUARE METRE (M<sup>2</sup>) AREAS  
 ALL DISTANCES ARE IN METRES.

*Ronald Brown*  
 October 26 1988

B.C.L.S.  
 1988

FILED VAVAS2055 L82418 2003-10-16-11.54.15.480949

CROSS - SECTIONS  
PHASE II

STRATA PLAN VR 2055

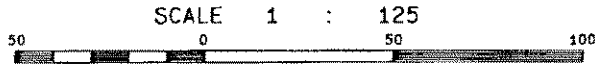

BUILDING 11  
CROSS-SECTION 'L-L'

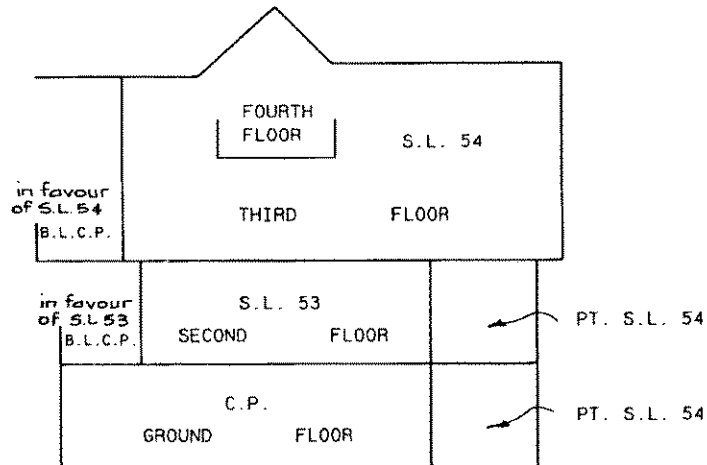

NOTE:

- S.L. DENOTES STRATA LOT
  - C.P. DENOTES COMMON PROPERTY
  - L.C.P. DENOTES LIMITED COMMON PROPERTY
  - C.F. DENOTES COMMON FACILITY
  - PT. DENOTES PART
  - B. DENOTES BALCONY
- BALCONIES ARE COMMON PROPERTY AND ARE NOT INCLUDED IN SQUARE METRE (M<sup>2</sup>) AREAS  
ALL DISTANCES ARE IN METRES.

*Ronald Brown*

B.C.L.S.

October 26 1988

FILED VAVAS2055 2003-10-16-11:54:16-480949

FILED



PLAN OF L.C.P. FOR STRATA LOTS

SHEET 40 OF 41 SHEETS

38-41, 45 & 46

STRATA PLAN VR 2055

PHASE II

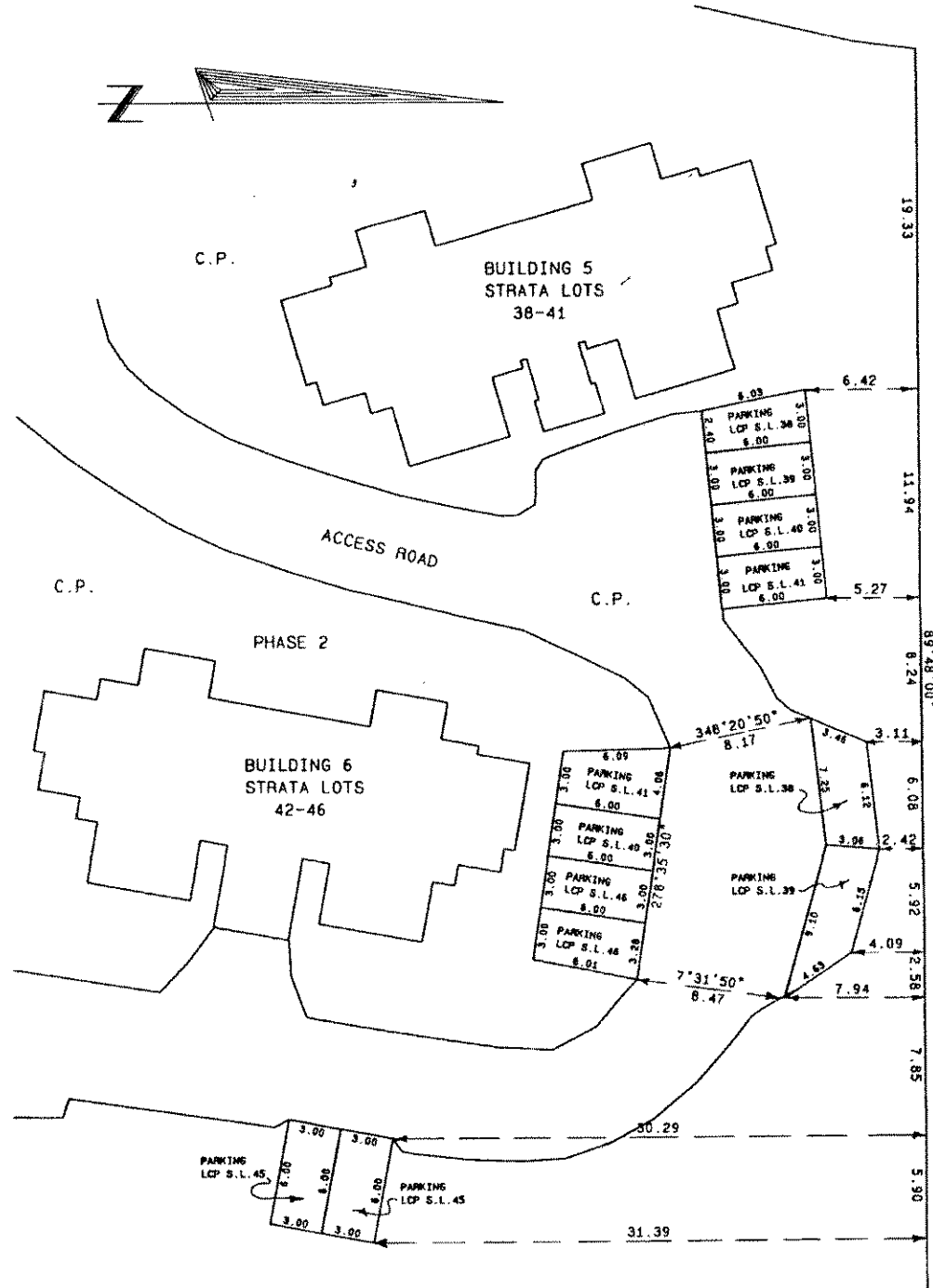

NOTE:  
 C.P. DENOTES COMMON PROPERTY  
 L.C.P. DENOTES LIMITED COMMON PROPERTY

*Ray Brown* B.C.L.S.  
 October 26 1988

FILED 182418 2003-10-16-11.54.16.480949

VAVAS2055

FILED



PLAN OF L.C.P. FOR STRATA LOTS

42-44 & 47-52

STRATA PLAN VR 2055

PHASE II

SCALE 1 : 250

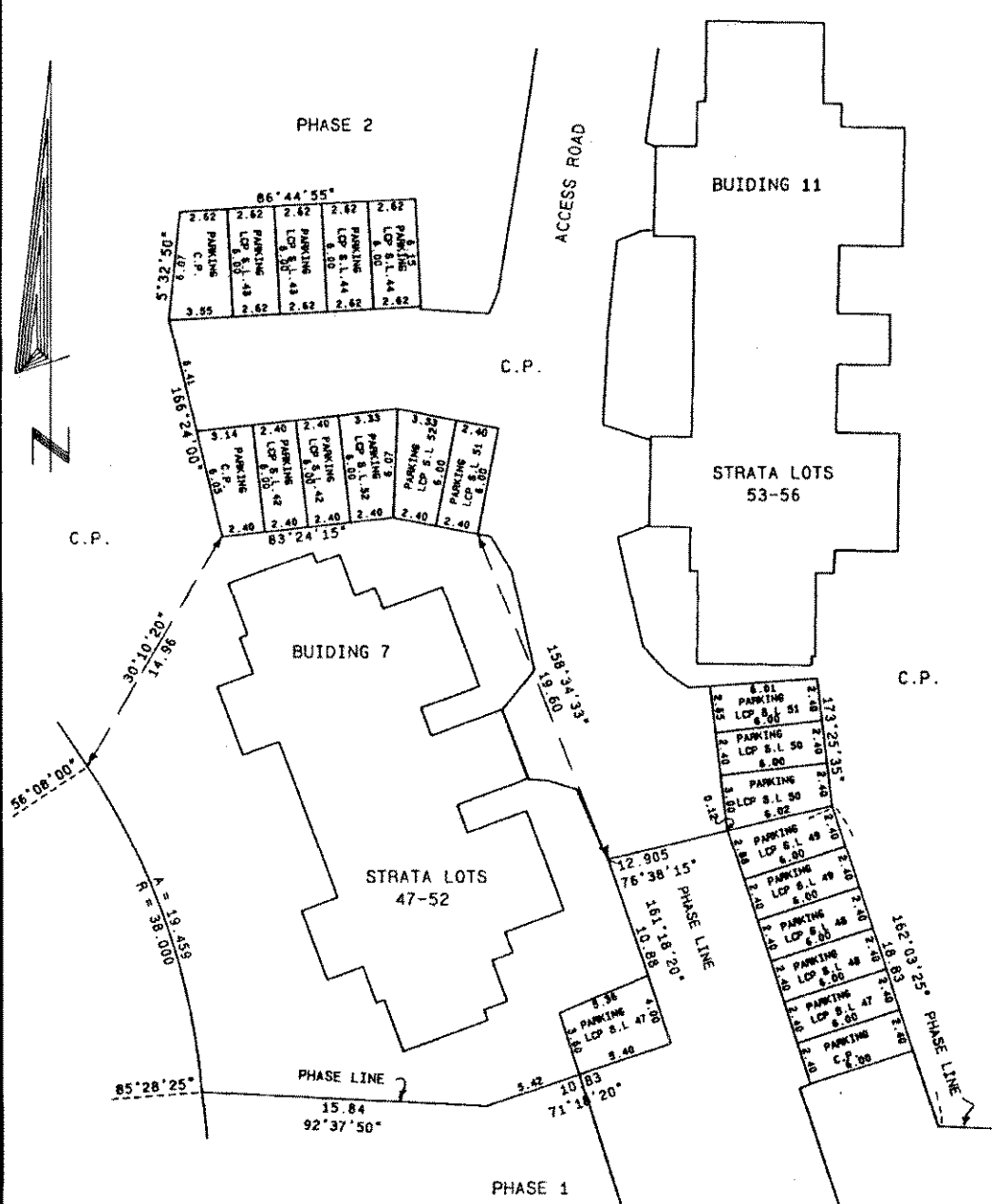

NOTE:  
 C.P. DENOTES COMMON PROPERTY  
 L.C.P. DENOTES LIMITED COMMON PROPERTY

*Bruce Brown* B.C.L.S.  
 October 26 1988

FILED VAVAS2055 L82418 2003-10-16-11-54.16.480949