

STRATA PLAN OF LOT 1, D.L. 7765,
PLAN LMP 54308, Gp. 1, N.W.D.

B.C.G.S. 92J.016

SCALE 1 : 1000

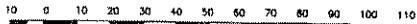

THIS PLAN LIES WITHIN THE SQUAMISH-LILLOOET REGIONAL DISTRICT

RESORT MUNICIPALITY OF WHISTLER

THE ADDRESS FOR SERVICE OF DOCUMENTS
ON THE STRATA CORPORATION IS:

THE OWNERS STRATA PLAN LMS 4697
C/O INTRAWEST/TALUSWOOD DEVELOPMENT LTD.
(INC. No. 472683)
800-200 BURRARD STREET
VANCOUVER, B.C.
V6C 3L6

CMC ADDRESS : 2324 TALUSWOOD PLACE
WHISTLER, B.C.

LEGEND

Bearings are Astronomic and are
derived from Plan LMP 54308

- ⊙ Standard Capped Post Found
- Standard Iron Post Found

All Distances are in Metres
For Building dimensions see
Individual Strata Lots

STRATA PLAN LMS 4697

DEPOSITED AND REGISTERED IN THE LAND
TITLE OFFICE AT NEW WESTMINSTER, B.C.
This 7 Day of June, 2002.

B. Brown / DS
Deputy REGISTRAR

KEY PLAN BT196856-865

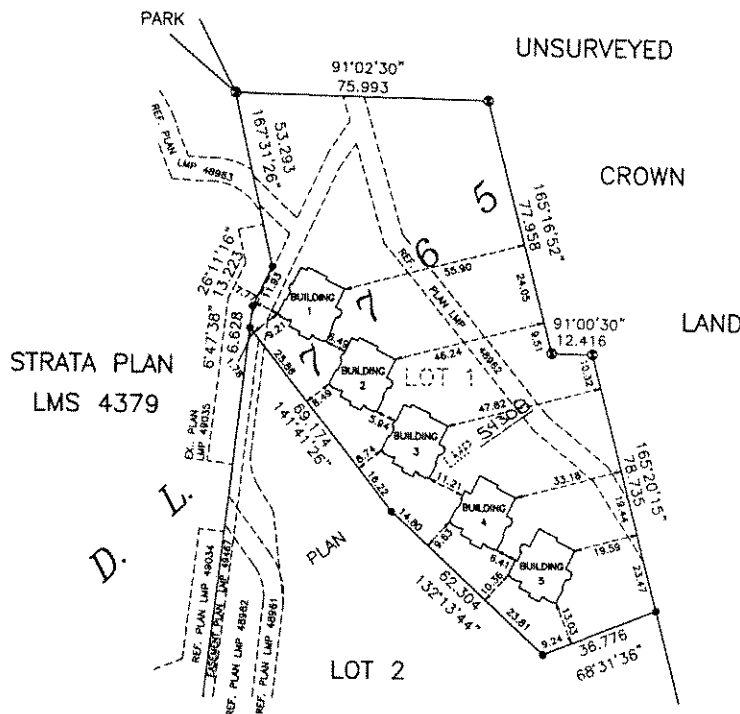

I, BRIAN O. BROWN, A BRITISH COLUMBIA LAND SURVEYOR,
CERTIFY THAT THE BUILDINGS INCLUDED IN THIS STRATA
PLAN HAVE NOT, AS OF THE 26th DAY OF APRIL, 2002,
BEEN PREVIOUSLY OCCUPIED.

Brian Brown B.C.L.S.

I, BRIAN O. BROWN, A BRITISH COLUMBIA LAND SURVEYOR,
CERTIFY THAT THE BUILDINGS SHOWN ON THIS STRATA
PLAN ARE WITHIN THE EXTERNAL BOUNDARIES OF THE
LAND THAT IS THE SUBJECT OF THE STRATA PLAN
DATED THIS 26th DAY OF APRIL, 2002.

Brian Brown B.C.L.S.

R. B. Brown Land Surveying Ltd.
Professional Land Surveyors
P.O. Box 13, Whistler, B.C. V0N 1B0
604-932-5426 Fax 604-938-1361
E-mail rbb@direct.ca

J96187

PLAN OF S.L.'s 1 AND 2

STRATA PLAN LMS 4697

SHEET 3 OF 9 SHEETS

SCALE 1 : 200



BUILDING 1

LOWER FLOOR

A ↴

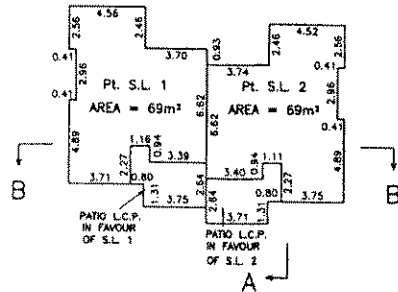

MAIN FLOOR

A ↴

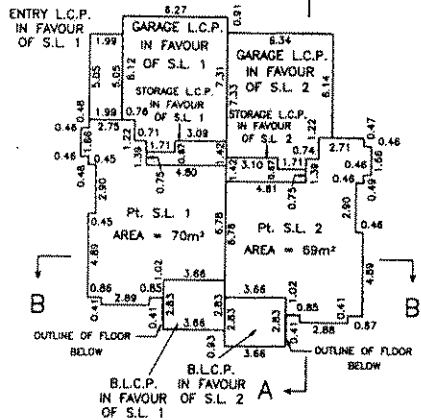

UPPER FLOOR

A ↴

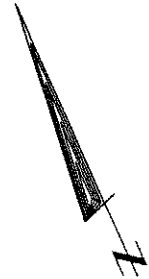
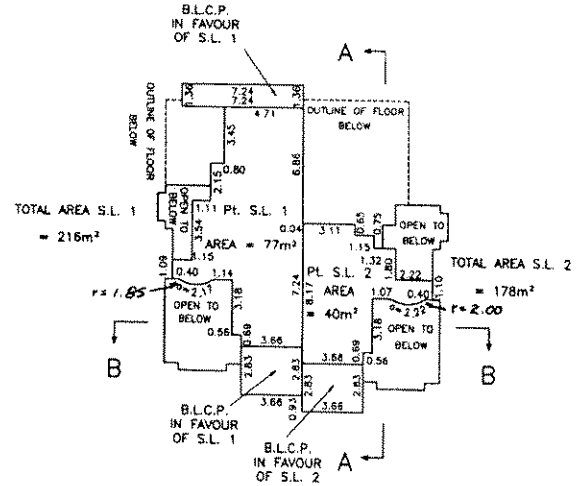

NOTE:
 S.L. DENOTES STRATA LOT
 L.C.P. DENOTES LIMITED COMMON PROPERTY
 PL DENOTES PART
 C.P. DENOTES COMMON PROPERTY
 B.L.C.P. DENOTES BALCONY LIMITED COMMON PROPERTY
 BALCONIES ARE LIMITED COMMON PROPERTY AND ARE NOT INCLUDED IN SQUARE METRE (m²) AREAS
 ALL DISTANCES ARE IN METRES.

R. B. Brown Land Surveying Ltd.
 Professional Land Surveyors
 P.O. Box 13, Whistler, B.C. V0N 1B0
 604-932-5426 Fax 604-938-1361
 E-mail rbb@direct.ca

BB
 April 26, 2002. B.C.L.S.

PLAN OF S.L.'s 3 AND 4

STRATA PLAN LMS 4697

SHEET 4 OF 9 SHEETS

SCALE 1 : 200



BUILDING 2

LOWER FLOOR

UPPER FLOOR

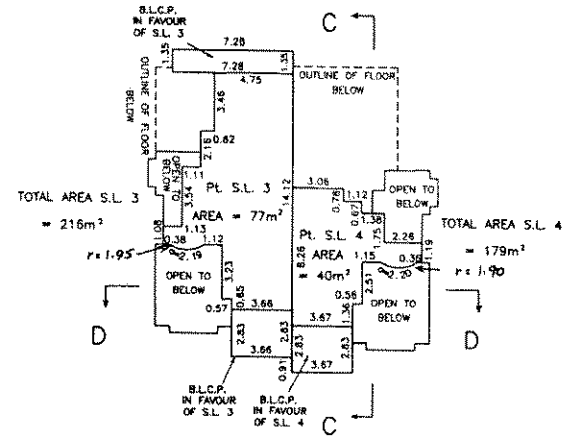
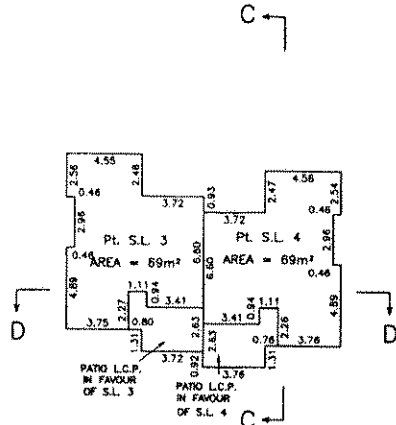

MAIN FLOOR

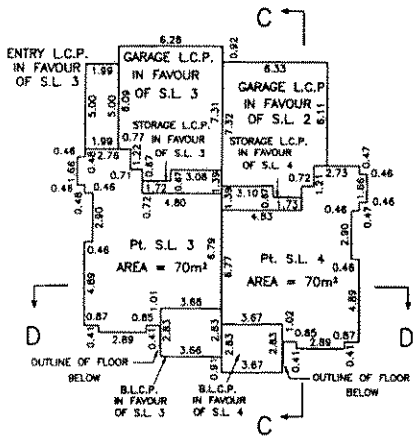

NOTE:
 S.L. DENOTES STRATA LOT
 L.C.P. DENOTES LIMITED COMMON PROPERTY
 PT. DENOTES PART
 C.P. DENOTES COMMON PROPERTY
 B.L.C.P. DENOTES BALCONY LIMITED COMMON PROPERTY
 BALCONIES ARE LIMITED COMMON PROPERTY AND ARE NOT INCLUDED IN SQUARE METRE (m²) AREAS
 ALL DISTANCES ARE IN METRES.

R. B. Brown Land Surveying Ltd.
 Professional Land Surveyors
 P.O. Box 13, Whistler, B.C. VON 1B0
 604-932-5426 Fax 604-938-1361
 E-mail rbb@direct.ca

BB
April 26, 2002. B.C.L.S.

PLAN OF S.L.'s 5 AND 6

STRATA PLAN LMS 4697

SHEET 5 OF 9 SHEETS

SCALE 1 : 200



BUILDING 3

LOWER FLOOR

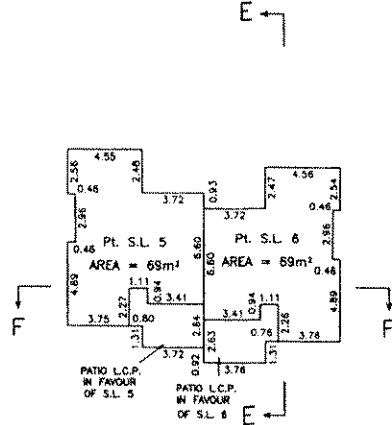

MAIN FLOOR

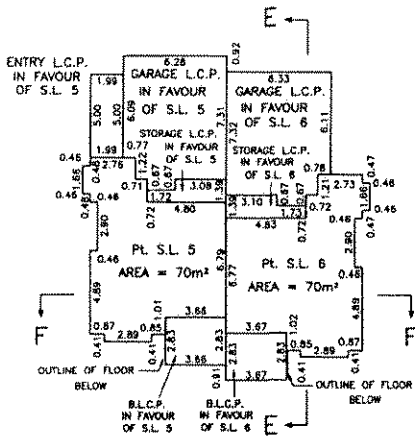

UPPER FLOOR

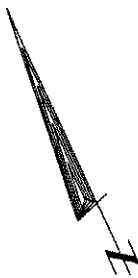
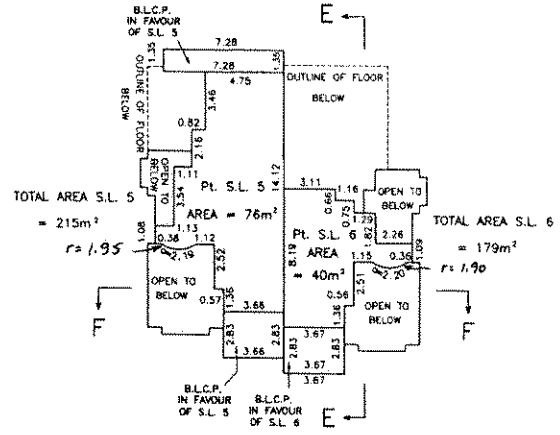

NOTE:
 S.L. DENOTES STRATA LOT
 L.C.P. DENOTES LIMITED COMMON PROPERTY
 Pt. DENOTES PART
 C.P. DENOTES COMMON PROPERTY
 B.L.C.P. DENOTES BALCONY LIMITED COMMON PROPERTY
 BALCONIES ARE LIMITED COMMON PROPERTY AND ARE NOT INCLUDED IN SQUARE METRE (m²) AREAS
 ALL DISTANCES ARE IN METRES.

R. B. Brown Land Surveying Ltd.
 Professional Land Surveyors
 P.O. Box 13, Whistler, B.C. V0N 1B0
 604-932-5426 Fax 604-938-1361
 E-mail rbb@direct.ca

RB
 April 26, 2002. B.C.L.S.

PLAN OF S.L.'s 7 AND 8

STRATA PLAN LMS 4697

SHEET 6 OF 9 SHEETS

SCALE 1 : 200



BUILDING 4

LOWER FLOOR

UPPER FLOOR

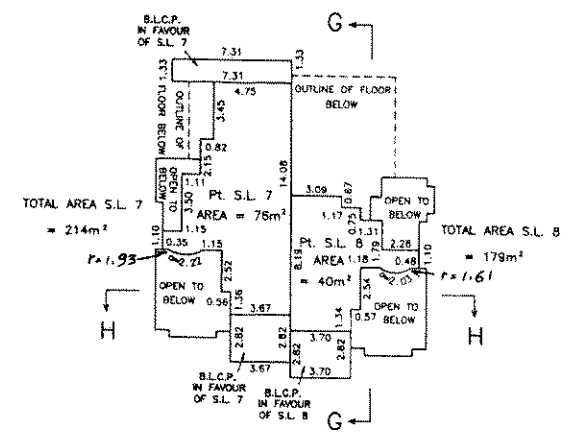
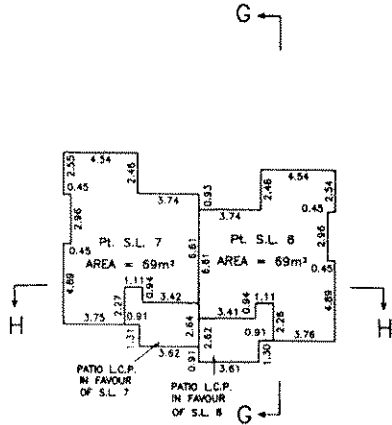

MAIN FLOOR

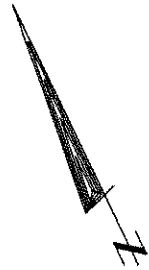
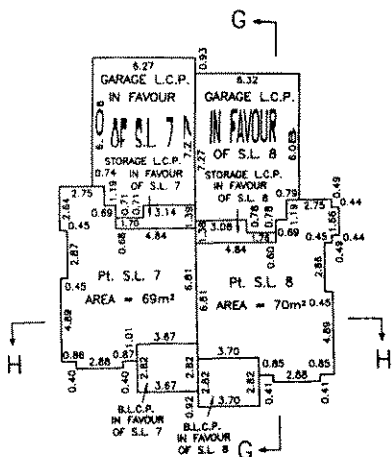

NOTE:
 S.L. DENOTES STRATA LOT
 L.C.P. DENOTES LIMITED COMMON PROPERTY
 Pt. DENOTES PART
 C.P. DENOTES COMMON PROPERTY
 B.L.C.P. DENOTES BALCONY LIMITED COMMON PROPERTY
 BALCONIES ARE LIMITED COMMON PROPERTY AND ARE NOT INCLUDED IN SQUARE METRE (m²) AREAS
 ALL DISTANCES ARE IN METRES.

R. B. Brown Land Surveying Ltd.
 Professional Land Surveyors
 P.O. Box 13, Whistler, B.C. V0N 1B0
 604-932-5426 Fax 604-938-1361

BB
 April 26, 2002. B.C.L.S.

PLAN OF S.L.'s 9 AND 10

STRATA PLAN LMS 4697

SHEET 7 OF 9 SHEETS

SCALE 1 : 200



BUILDING 5

LOWER FLOOR

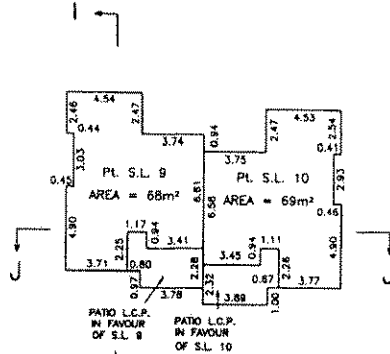

UPPER FLOOR

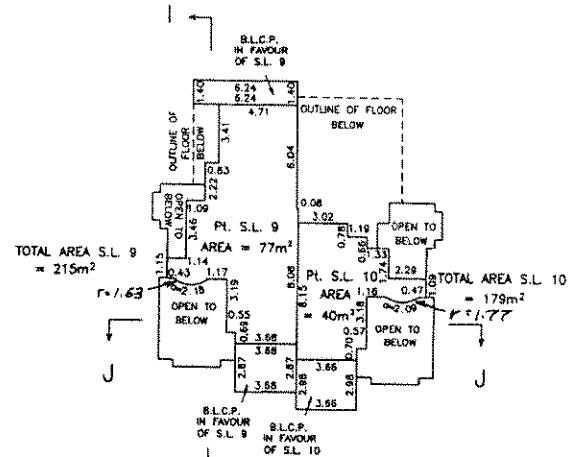

MAIN FLOOR

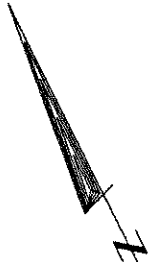
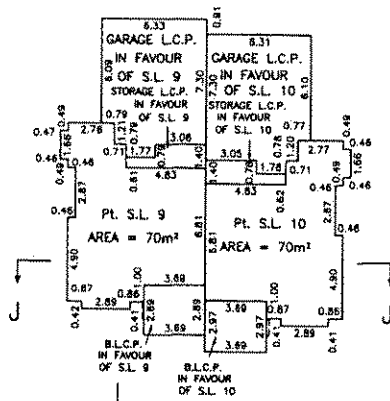

NOTE:
 S.L. DENOTES STRATA LOT
 L.C.P. DENOTES LIMITED COMMON PROPERTY
 PL. DENOTES PART
 C.P. DENOTES COMMON PROPERTY
 B.L.C.P. DENOTES BALCONY LIMITED COMMON PROPERTY
 BALCONIES ARE LIMITED COMMON PROPERTY AND ARE NOT INCLUDED IN SQUARE METRE (m²) AREAS
 ALL DISTANCES ARE IN METRES.

R. B. Brown Land Surveying Ltd.
 Professional Land Surveyors
 P.O. Box 13, Whistler, B.C. V0N 1B0
 604-932-5426 Fax 604-938-1361
 E-mail rbb@direct.ca

RB
 April 26, 2002. B.C.L.S.

CROSS SECTIONS

STRATA PLAN LMS 4697

SCALE 1 : 200

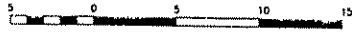

BUILDING 1

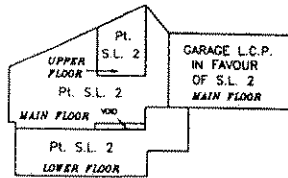

SECTION A - A

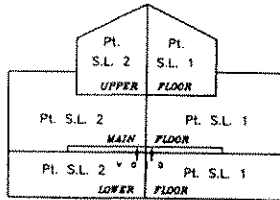

SECTION B - B

BUILDING 2

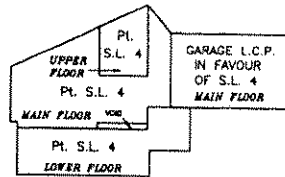

SECTION C - C

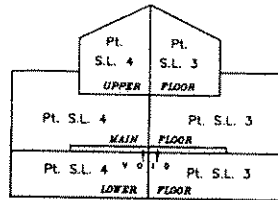

SECTION D - D

BUILDING 3

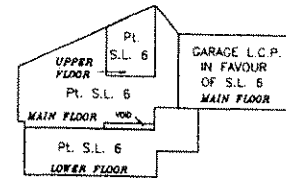

SECTION E - E

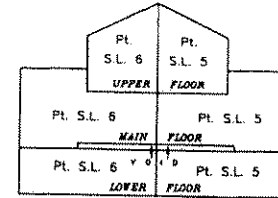

SECTION F - F

NOTE:
 S.L. DENOTES STRATA LOT
 L.C.P. DENOTES LIMITED COMMON PROPERTY
 Pt. DENOTES PART
 C.P. DENOTES COMMON PROPERTY
 B.L.C.P. DENOTES BALCONY LIMITED COMMON PROPERTY
 BALCONIES ARE LIMITED COMMON PROPERTY AND ARE NOT INCLUDED IN SQUARE METRE (m²) AREAS
 ALL DISTANCES ARE IN METRES.

R. B. Brown Land Surveying Ltd.
 Professional Land Surveyors
 P.O. Box 13, Whistler, B.C. V0N 1B0
 604-932-5426 Fax 604-938-1361
 E-mail rbb@direct.ca

RB
April 26, B.C.L.S.
 2002.

CROSS SECTIONS

STRATA PLAN LMS 4697 SHEET 9 OF 9 SHEETS

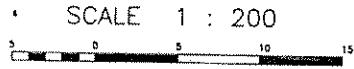

BUILDING 4

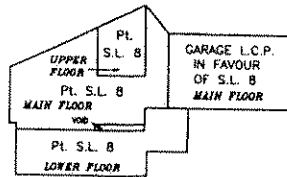

SECTION G - G

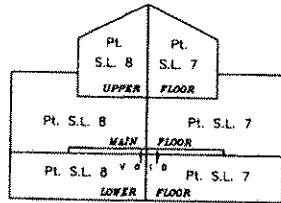

SECTION H - H

BUILDING 5

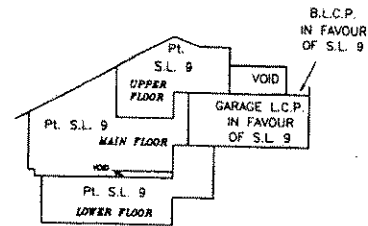

SECTION I - I

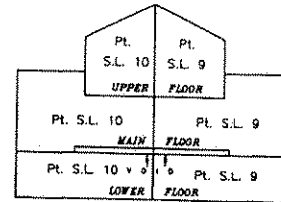

SECTION J - J

NOTE:
 S.L. DENOTES STRATA LOT
 L.C.P. DENOTES LIMITED COMMON PROPERTY
 Pt. DENOTES PART
 C.P. DENOTES COMMON PROPERTY
 B.L.C.P. DENOTES BALCONY LIMITED COMMON PROPERTY
 BALCONIES ARE LIMITED COMMON PROPERTY AND ARE NOT INCLUDED IN SQUARE METRE (m²) AREAS
 ALL DISTANCES ARE IN METRES.

R. B. Brown Land Surveying Ltd.
 Professional Land Surveyors
 P.O. Box 13, Whistler, B.C. V0N 1B0
 604-932-5426 Fax 604-938-1361
 E-mail rbb@direct.ca

RB
 April 26, 2002 B.C.L.S.