

STRATA PLAN OF LOT 1, D.L. 7765,
 PLAN LMP 54308, Gr. 1, N.W.D.

B.C.G.S. 921016

SCALE 1 : 1000



THIS PLAN LIES WITHIN THE SQUAMISH-LILLOOET REGIONAL DISTRICT

RESORT MUNICIPALITY OF WHISTLER

THE ADDRESS FOR SERVICE OF DOCUMENTS
 ON THE STRATA CORPORATION IS:

THE OWNERS STRATA PLAN LMS 4697
 C/O INTRAWEST/TALUSWOOD DEVELOPMENT LTD.
 (INC. NO. 472803)
 800-200 BURBARD STREET
 VANCOUVER, B.C.
 V6C 3L6

CIVIC ADDRESS : 2324 TALUSWOOD PLACE
 WHISTLER, B.C.

- LEGEND**
- ⊙ Bearings are Astronomic and are derived from Plan LMP 54308
 - Standard Copied Post Found
 - ⊕ Standard Iron Post Found
- All Distances are in Meters
 For Building dimensions see Individual Strata Lots

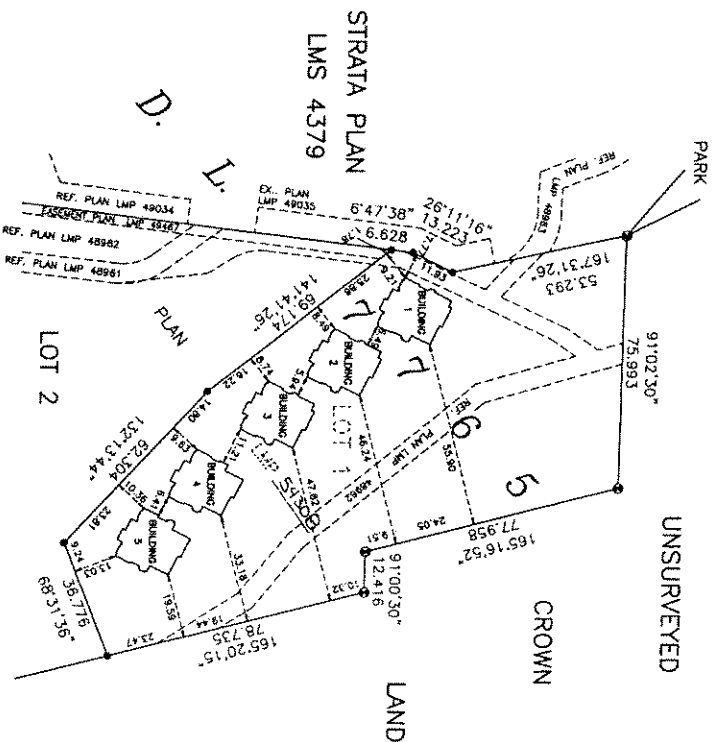

STRATA PLAN LMS 4697
 DEPOSITED AND REGISTERED IN THE LAND
 TITLE OFFICE AT NEW WESTMINSTER, B.C.
 This 7 day of June, 2002.

B. Brown / IS
 Deputy REGISTRAR
 KEY PLAN BT196856-865

I, BRIAN O. BROWN, A BRITISH COLUMBIA LAND SURVEYOR,
 CERTIFY THAT THE BUILDINGS SHOWN ON THIS STRATA
 PLAN ARE THE EXTERNAL BOUNDARIES OF THE
 LAND THAT IS THE SUBJECT OF THE STRATA PLAN
 DATED THIS 26th DAY OF APRIL, 2002.

Brian O. Brown
 B.C.L.S.

R. B. Brown Land Surveying Ltd.
 Professional Land Surveyors
 P.O. Box 13, Whistler, B.C. V0N 1B0
 604-932-5426 Fax 604-938-1361
 E-mail: rbb@rdc.ca

PLAN OF S.L.'s 1 AND 2

SCALE 1 : 200



LOWER FLOOR

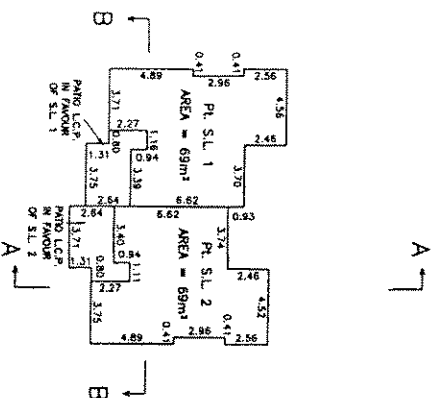

MAIN FLOOR

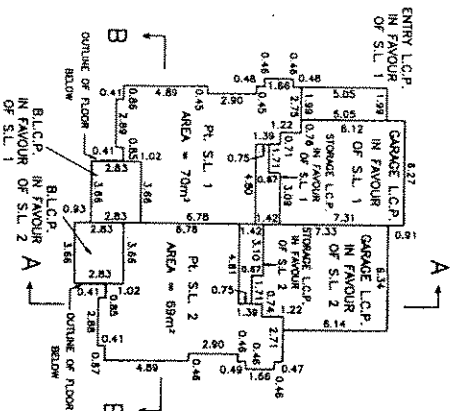

BUILDING 1

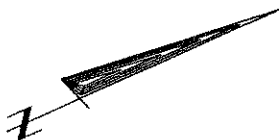

UPPER FLOOR

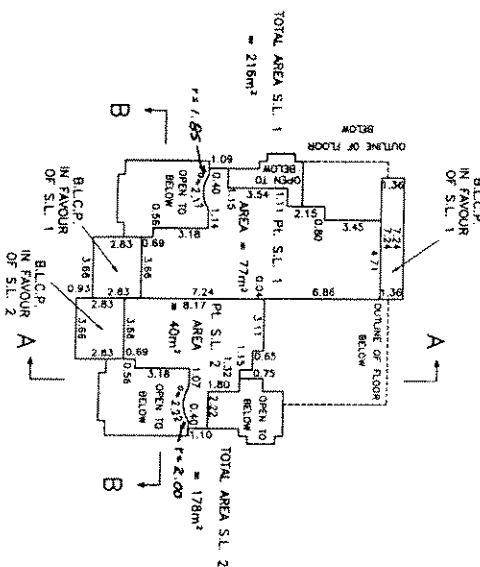

STRATA PLAN LMS 4697

SHEET 3 OF 3 SHEETS

NOTE:
 S.L. DENOTES STRATA LOT
 L.C.P. DENOTES LIMITED COMMON PROPERTY
 P.L. DENOTES PARKING
 C.P. DENOTES COMMON PROPERTY
 B.L.C.P. DENOTES BALCONY LIMITED COMMON PROPERTY
 B.L.C.P. DENOTES BALCONY LIMITED COMMON PROPERTY
 BALCONIES ARE LIMITED COMMON PROPERTY AND ARE NOT INCLUDED IN SQUARE METRE (m²) AREAS
 ALL DISTANCES ARE IN METRES.

R. B. Brown Land Surveying Ltd.
 Professional Land Surveyors
 P.O. Box 13, Whistler, B.C. V0N 1B0
 604-932-5428 Fax 604-938-1361
 E-mail rbb@direct.ca

38/187

FILE : DATA\WHISTLER\LOOKOUT PROJECS SP02036C

BB
 April 26, 2002

B.C.L.S.
 2002

PLAN OF S.L.'s 3 AND 4

STRATA PLAN LMS 4697

SHEET 4 OF 8 SHEETS

SCALE 1 : 200

BUILDING 2

LOWER FLOOR

UPPER FLOOR

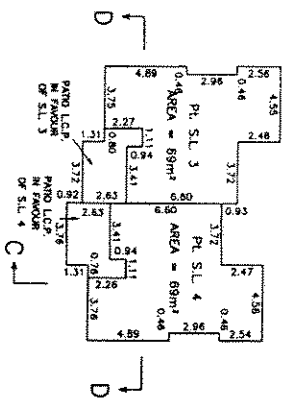

MAIN FLOOR

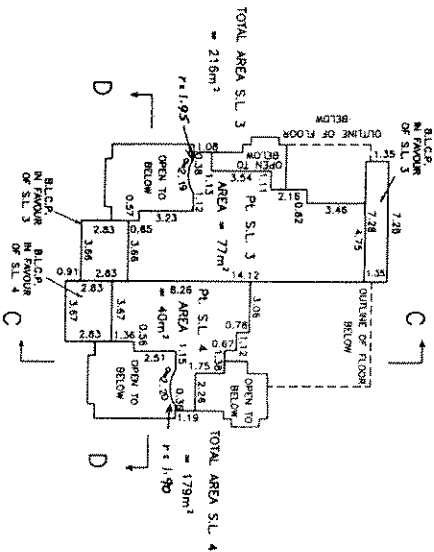
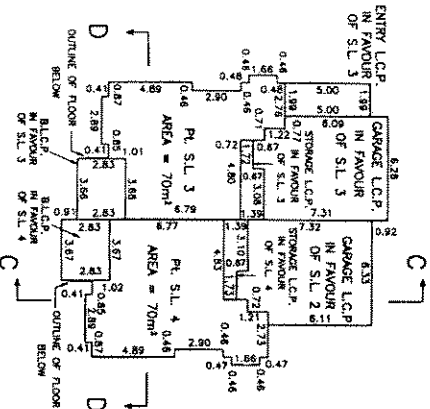

- NOTE:
- S.L. DENOTES STRATA LOT
 - L.C.P. DENOTES LIMITED COMMON PROPERTY
 - PL. DENOTES PART
 - C.P. DENOTES COMMON PROPERTY
 - B.L.C.P. DENOTES BALCONY LIMITED COMMON PROPERTY
 - BALCONIES ARE LIMITED COMMON PROPERTY AND ARE NOT INCLUDED IN SQUARE METRE (m²) AREAS
 - ALL DISTANCES ARE IN METRES.

R. B. Brown Land Surveying Ltd.
Professional Land Surveyors
P.O. Box 13, Whistler, B.C. V0N 1B0
604-932-5428 Fax: 604-938-1361
E-mail: rbb@rdirect.ca

RB
April 26, 2002 B.C.L.S.

PLAN OF S.L.'S 5 AND 6

STRATA PLAN LMS 4697

SHEET 5 OF 9 SHEETS

SCALE 1 : 200

BUILDING 3

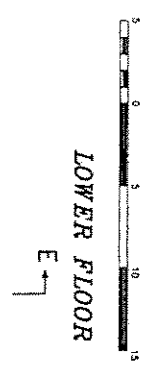

MAIN FLOOR

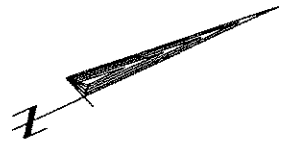
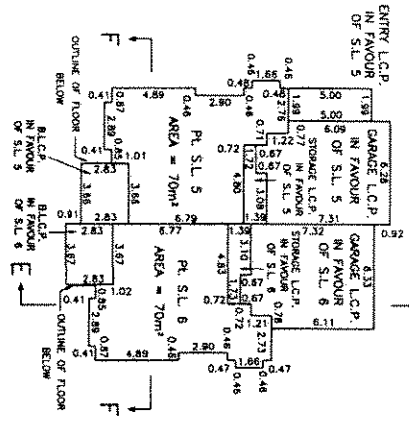

UPPER FLOOR

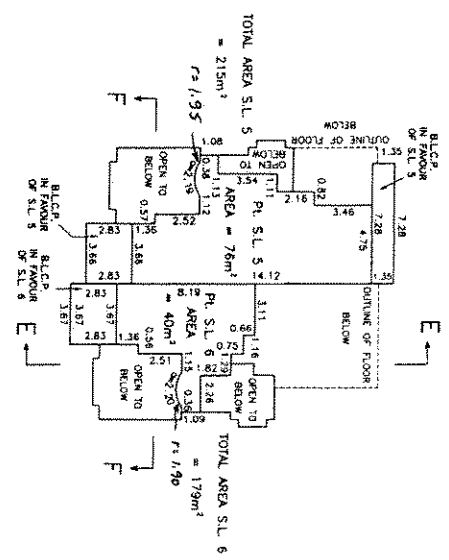

- NOTE:**
- S.L. DENOTES STRATA LOT
 - L.C.P. DENOTES LIMITED COMMON PROPERTY
 - P. DENOTES PART
 - C.P. DENOTES COMMON PROPERTY
 - B.L.C.P. DENOTES BALCONY LIMITED COMMON PROPERTY
 - BALCONIES ARE LIMITED COMMON PROPERTY AND ARE NOT INCLUDED IN SQUARE METRE (m²) AREAS
 - ALL DISTANCES ARE IN METRES.

R. B. Brown Land Surveying Ltd.
 Professional Land Surveyors
 P.O. Box 13, Whistler, B.C. V0N 1B0
 604-932-5426 Fax 604-938-1361
 E-mail rbb@direct.ca

06187

BB
 April 26, 2002

B.C.L.S.

PLAN OF S.L.'s 7 AND 8

SCALE 1 : 200



LOWER FLOOR

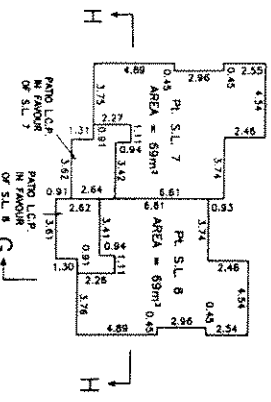

MAIN FLOOR

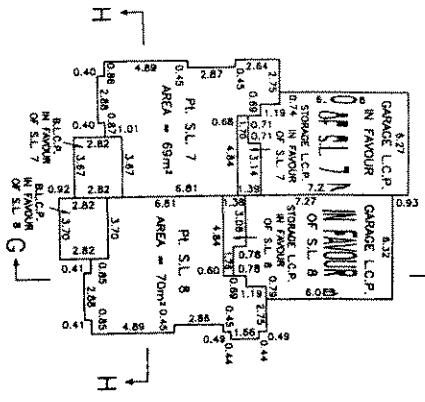

BUILDING 4

UPPER FLOOR

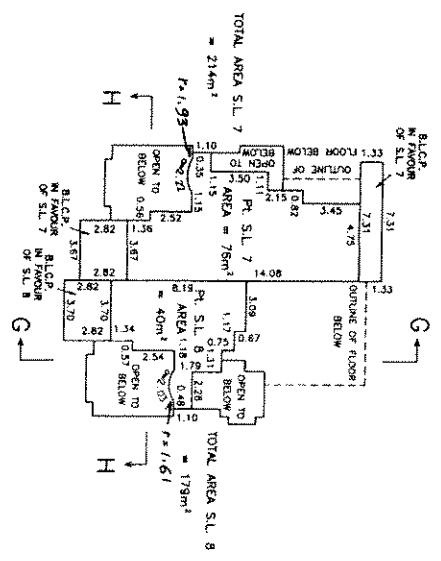

STRATA PLAN LMS 4697

SHEET 6 OF 9 SHEETS

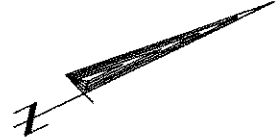

- NOTE:
- S.L. DENOTES STRATA LOT
 - L.C.P. DENOTES LIMITED COMMON PROPERTY
 - PL. DENOTES PART
 - C.P. DENOTES COMMON PROPERTY
 - B.L.C.P. DENOTES BALCONY LIMITED COMMON PROPERTY
 - BALCONIES ARE LIMITED COMMON PROPERTY AND ARE NOT INCLUDED IN SQUARE METRE (m²) AREAS
 - ALL DISTANCES ARE IN METRES.

R. B. Brown Land Surveying Ltd.
 Professional Land Surveyors
 P.O. Box 13, Whittier, B.C. V0N 1B0
 604-932-5426 Fax 604-938-1351



395783

FILE : DATA\WHITTIER\LOOKOUT PAGE6 SP020386

BB
 April 26, 2002

B.C.L.S.
 2002

PLAN OF S.L.'s 9 AND 10

SCALE 1 : 200



LOWER FLOOR

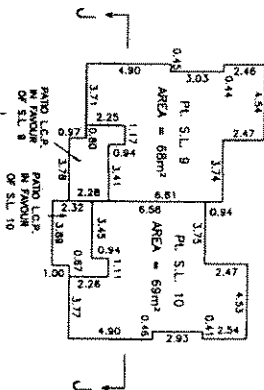

MAIN FLOOR

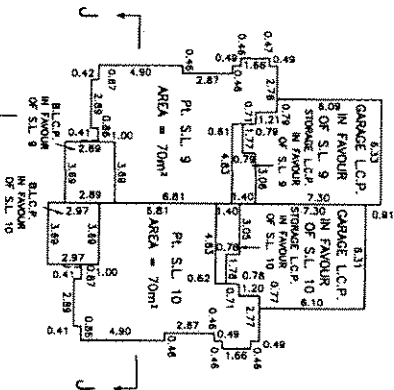

BUILDING 5

UPPER FLOOR

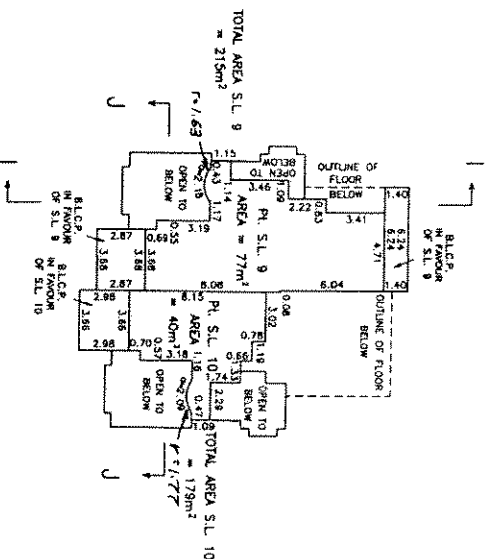

STRATA PLAN LMS 4697

SHEET 7 OF 9 SHEETS

- NOTE:
- S.L. DENOTES STRATA LOT
 - L.C.P. DENOTES LIMITED COMMON PROPERTY
 - PL DENOTES PART
 - C.P. DENOTES COMMON PROPERTY
 - B.L.C.P. DENOTES BALCONY LIMITED COMMON PROPERTY
 - BALCONIES ARE LIMITED COMMON PROPERTY AND ARE NOT INCLUDED IN SQUARE METRE (m²) AREAS
 - ALL DISTANCES ARE IN METRES.

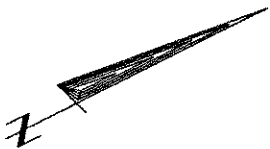

R. B. Brown Land Surveying Ltd.
 Professional Land Surveyors
 P.O. Box 13, Whistler, B.C. V0N 1B0
 604-932-5428 Fax 604-938-1361
 E-mail rbs@dncltd

JS6187

[Signature]
 April 26, 2002
 B.C.L.S.

CROSS SECTIONS

STRATA PLAN LMS

SHEET 8 OF 9 SHEETS
4697

SCALE 1 : 200



BUILDING 1

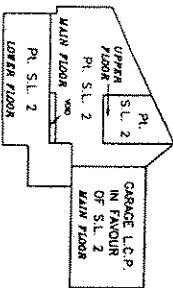

SECTION A - A

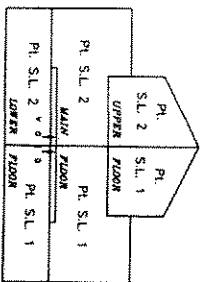

SECTION B - B

BUILDING 2

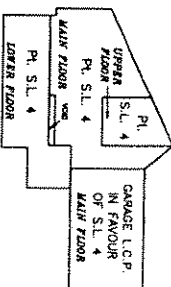

SECTION C - C

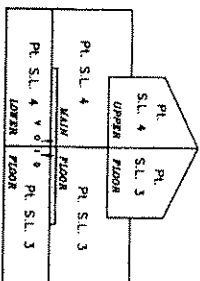

SECTION D - D

BUILDING 3

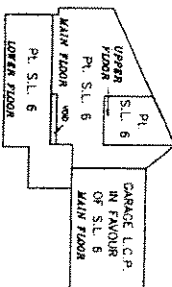

SECTION E - E

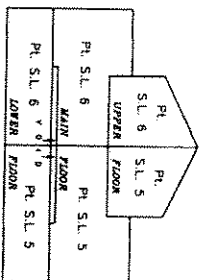

SECTION F - F

NOTE:
 S.L. DENOTES STRATA LOT
 L.C.P. DENOTES LIMITED COMMON PROPERTY
 Pt. DENOTES PART
 C/P DENOTES COMMON PROPERTY
 B.L.C.P. DENOTES BALCONY LIMITED COMMON PROPERTY
 BALCONIES ARE LIMITED COMMON PROPERTY AND ARE NOT INCLUDED IN SQUARE METRE (m²) AREAS
 ALL DISTANCES ARE IN METRES.

R. B. Brown Land Surveying Ltd.
 Professional Land Surveyors
 P.O. Box 13, Whistler, B.C. V0N 1B0
 604-932-5426 Fax 604-938-1381
 E-mail rbb@direct.ca

J96187

BB
 April 26, 2002

B.C.L.S.
 2002

CROSS SECTIONS



STRATA PLAN LMS 4697

SHEET 9 OF 9 SHEETS

BUILDING 4

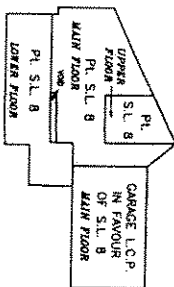

SECTION G - G

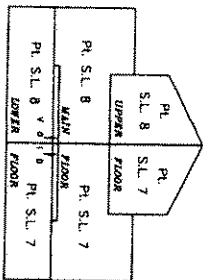

SECTION H - H

BUILDING 5

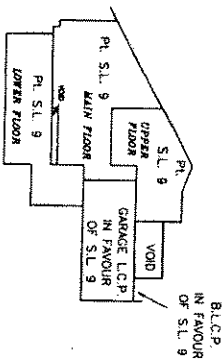

SECTION I - I

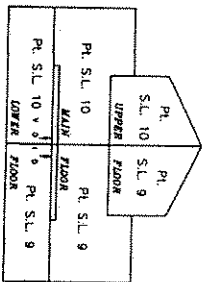

SECTION J - J

NOTE:
 S.L.P. DENOTES STRATA LOT
 L.C.P. DENOTES LIMITED COMMON PROPERTY
 P.L. DENOTES PART
 C.P. DENOTES COMMON PROPERTY
 B.L.C.P. DENOTES BALCONY LIMITED COMMON PROPERTY
 BALCONIES ARE LIMITED COMMON PROPERTY AND ARE NOT INCLUDED IN SQUARE METRE (m²) AREAS
 ALL DISTANCES ARE IN METRES.

R. B. Brown Land Surveying Ltd.
 Professional Land Surveyors
 P.O. Box 13, Whistler, B.C. V0N 1B0
 604-932-9426 Fax 604-938-1361
 E-mail rbb@direct.ca

196187

RB
 April 26, 2002